

## Multi-Point Level Switch

The Series LC-30 is a multi-point level switch for liquids. It's operation is based on a float containing a magnetic field switching a contact as it passes along a guide. It can provide one point for an alarm or up to 9 points for alarms and control.

The float can travel the length of a guide tube that contains bi-stable reed switches at the control/alarm points. As the float passes each switch, it activates it to provide an indication of whether the float is above or below the position of the switch. The LC-30 is designed for mounting above the tank but, under special circumstances, it can be mounted from the side.

The LC-30 has a simple design and is constructed from materials with good mechanical and corrosion resistance. Generally, it is used for:

- High & Low Level alarms.
- Stop/Start of pumps for level control.
- Level control in tanks for chemical dosing.
- Control of industrial processes.
- Monitoring & control of auxiliary tanks in power plants, chemical plants, textile industry etc.
- Construction with Ex enclosure, on request.

### Measurement Principle

The float activates a bi-stable reed switch by a magnet built into the float.

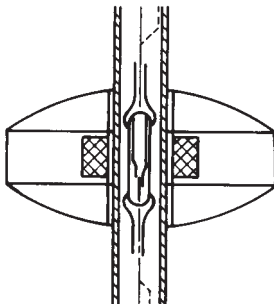
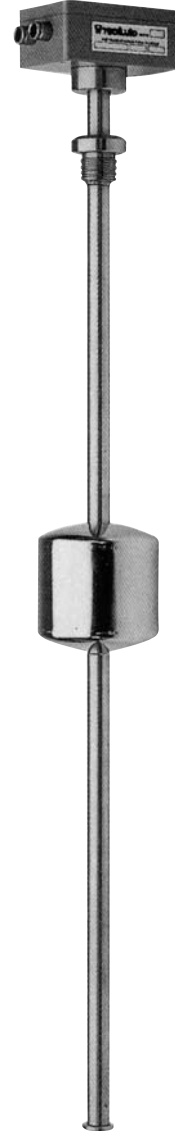

### Operation

Inside the guide tube, bi-stable reed switches are mounted at the alarm/control points. As the float passes the position where a reed switch is located, the magnetic field from the float activates the switch to leave it set indicating whether the float is above or below the position of the switch.

The maximum number of alarm or control points is 9.

## Technical Data

- Installation: Vertical
- Connection: DN-40, PN-16 DIN 2502 Flange (DN-25, DN-100 & DN-150 on request)
- Maximum Length: 6.0m in AISI-316  
2.5m in PVC, PTFE  
6.0m in PVC, PTFE (internal SS316 tube)
- Diameter of float: LC-30 = 110 mm  
LC-M11 = 52 mm
- Liquid density: From 0.45 to 3 kg/l
- Liquid viscosity: Maximum 1500 cSt.
- Precision:  $\pm 2$  mm
- Hysteresis:  $\pm 4$  mm
- Materials : AISI-316, PVC, PTFE.
- Pressure: PN-16 for AISI-316 and PVC or PTFE with internal SS-316 tube  
PN-10 for all PVC or PTFE
- Liquid Temperature:  $-20^{\circ}\text{C} + 150^{\circ}\text{C}$  AISI-316, PTFE  
 $0^{\circ}\text{C} + 50^{\circ}\text{C}$  PVC
- Ambient Temperature:  $-20^{\circ}\text{C} + 60^{\circ}\text{C}$  AISI-316, PTFE  
 $0^{\circ}\text{C} + 50^{\circ}\text{C}$  PVC
- Contacts: Reed 1A 220VA 60W/VA (Maximum 9 with minimum separation of 20 mm)

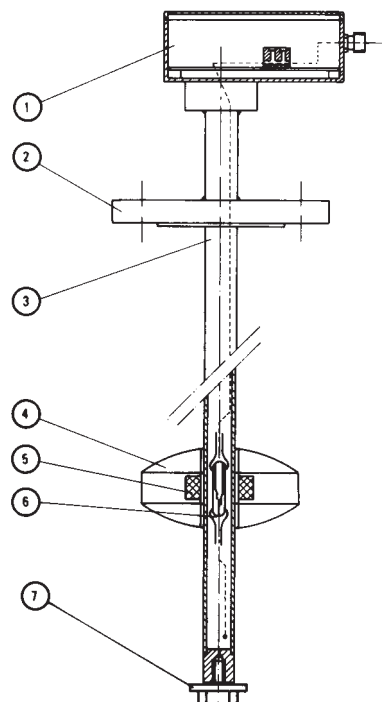

## Construction

N°.		Materials		
		LC-../SS	LC-../PVC	LC-../PTFE
1	Enclosure	Aluminium	Aluminium	Aluminium
2	Connection	AISI-316	PVC	PTFE
3	Guide/Tube	AISI-316	PVC	PTFE
4	Float	AISI-316	PVC	PTFE
5	Magnet	Supernialco	Supernialco	Supernialco
6	Contact	Reed	Reed	Reed
7	End	AISI-316	PVC	PTFE

## Reed Switches

The LC-30 has two types of contacts for level indication, RSC and Bi-Stable RBC. The difference is in the status of the contact once the float has passed the contact.

### Series RSC

The RSC is a reed switch without “memory”. It is only activated in presence of the magnetic field of the float. If the float moves away from the position of the switch, the switch returns to its non-active position, which is the same for the float being above or below the switch.

This system provides an indication of when the level is at the same position as the reed switch but will not provide an indication of the level away from this point. That is, it provides an indication of actual level but not high or low level.

### Series BI-STABLE RBC

The bi-stable RBC reed switch remains in its switched position after the float has passed. It will remain in one position when the float is below and remains in the opposite position while the float is above the reed switch. This provides a High/Low indication but will not indicate the exact position of the level.

## Level Switch Configurations

### Series LC-30

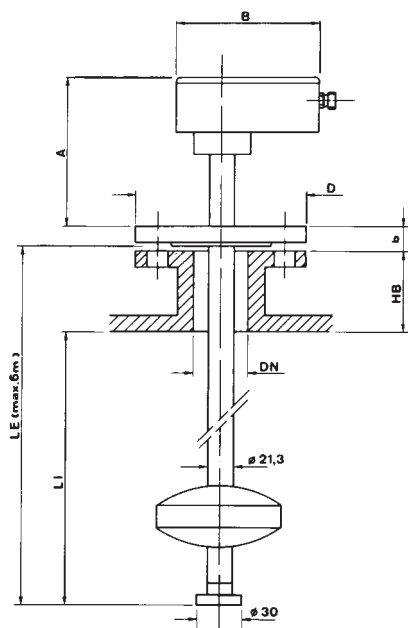

### Series LC-31

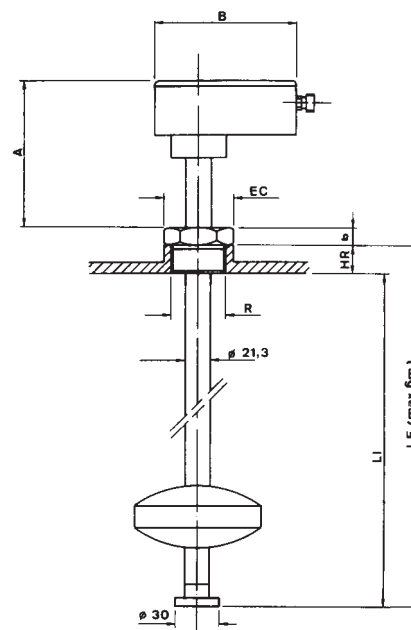

### Assembly with Flanges LC-30

DN	PN	D	g	k	1xN°	b	A	B	HB	LE	LI
25*	40	115	68	85	14x4	18	160	125	Related to the individual measuring range.		
40	40	150	88	110	18x4	18	160	125			
100*	16	220	158	180	18x8	20	160	125			
150*	16	285	212	240	23x8	22	160	125			

\* Normally DN-40, others on request.

### Assembly with Connection LC-31

R	EC	b	A	B	HR	LE	LI
1 1/2	60	22	160	125	30	= Range	

Other diameters and standards (NPT etc) available on request.

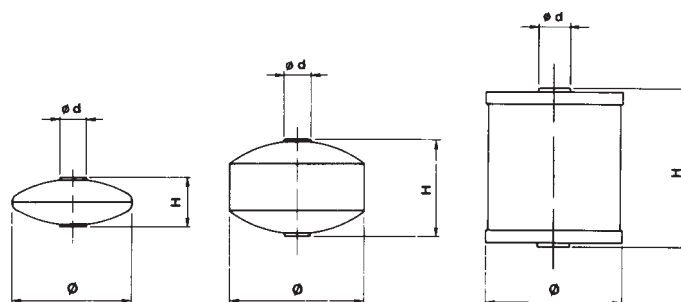

### Float Characteristics

Model	LCG811	LCG821	LCG831	LCG841	LCG883	LCG885	LCG889
Material	AISI-316	AISI-316	AISI-316	AISI-316	PVC	PTFE	PP
Max Press (Bar)	25	25	16	16	10	10	10
Density Min Kg/1	0.950	0.800	0.650	0.500	0.600	0.750	0.500
T <sup>a</sup> Max	150°C	150°C	150°C	150°C	150°C	150°C	150°C
$\phi$ mm	110	110	110	110	110	110	110
H mm	45	70	95	120	80	100	100
$\phi d$ mm	25	25	25	25	25	25	25

Other float designs and materials available on request.



## Level Switch Configurations Series LC-M12

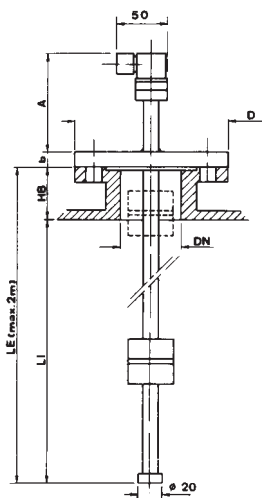

## Series LC-M11

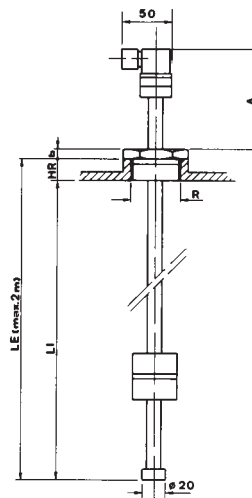

### Assembly with flange series LC-M12(AISI-316), M32(PVC), M52(PTFE), M92(PP)

DN	PN	D	k	g	1xN°.	b	A	HB	LE	LI
25	25	115	85	68	14x4	18	100	Related to range		

Other sizes and types on request.

### Assembly with Connection LC-M11

R	EC	b	A	HR	LE	LI
1 1/2"	60	22	100	30	Related to range	

Other diameters and standards (NPT etc), on request.

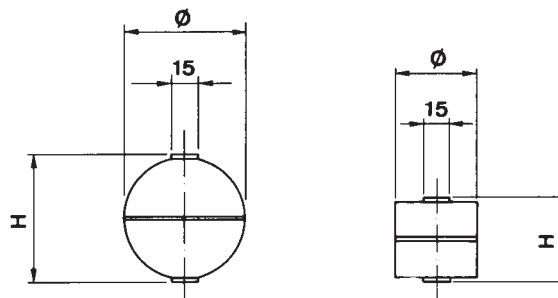

LCGM 11

LCGM 21  
LCGM 31/83/85/89

### Characteristics of the Floats

Model	LCGM11	LCGM21	LCGM31	LCGM83	LCGM85	LCGM89
Material	AISI-316	AISI-316	AISI-316	PVC	PTFE	PP
Max Press (Bar)	20	25	25	10	10	10
Density Min Kg/l	0.800	0.650	0.500	0.700	0.800	0.500
T <sup>a</sup> Max	150°C	150°C	150°C	45°C	150°C	95°C
∅ mm	52	82	110	38	60	38
H mm	51	82	120	60	60	38

Other float designs and materials available on request.

We are at your service, please consult us.  
TECFLUID develops and manufactures instruments for gases and liquids, using the most advanced techniques.  
Request Information by telephone n° 01 34 64 38 00

