



Liquid Level Gauges with Alarm & Transmitter Outputs

The level measurement is made by reading the position of a submerged rod (float) supported by a spring. The position is read with a magnetic coupling through a SS-316 wall, separating the instrumentation from the process. This design enables operation under extreme process conditions (very high temperatures, pressures and with corrosive fluids). The standard construction is in AISI-316, with the indicator enclosure in coated aluminium. The design is robust, simple and provides a reliable measurement of level under harsh process conditions. A local indication with the options of:

- High and low alarm contacts
- Electric output signal of 4-20 mA
- Pneumatic output signal of 3-15 psi or 0.2-1 bar

The LP-80 is used in a broad range of applications, such as:

- Chemical and Petrochemical
- Oil and Gas
- Steam/Power
- Food and beverage
- Storage of toxic products
- Monitoring and control of common processes

Measurement Principle

According to Archimedes principle of body submerged in a liquid.

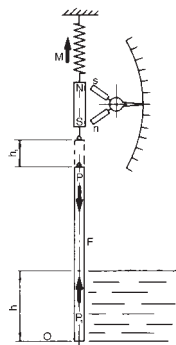

Operation

A "rod" with a density similar to the measured liquid is suspended by a spring to maintain an equilibrium with its weight.

A variation in liquid level produces a change in the weight of the rod (partially submerged), which can be measured by the extension of the spring that supports the rod. The variation in the length of the spring is transmitted to the indicating needle via a magnetic coupling between a magnet on the end of the spring and a magnet fixed to the indicator.

The rod is always immersed in the liquid (not floating on the surface). This measuring principle is well suited to dirty environments.

Technical Data

- Installation:
Vertically, above the tank
(Horizontally under special circumstances)
- Connections:
DN-40 Flanges PN-40 DIN 2502
1 1/2" BSP Screwed connections
(Others available on request)
- Range:
300 mm to 6 m
- Accuracy:
± 1.5% of the measured value
- Scale:
%, (height and volume on request)
- Working Pressure:
Standard: PN-40
Max: up to PN-400, on request
- Temperature of Liquid:
-60°C to 150°C (Standard)
-120°C to 400°C (On request)
- Ambient Temperature:
-10°C to 80°C (see transmitter data)
- High and Low Level Alarm Options:
AMM micro-switch contact, 6A, 240V
AMD inductive alarm with contact relay amplifier
WE 77/Ex1 or 2 contacts @ 3A/220V
- Signal Outputs:
TEH signal from 0...4-20 mA (4 wires).
TK signal from 0...4-20 mA, (2 wires, 12.7-36 VDC)
TKEX signal from 0...4-20 mA (2 wires, Intrinsically safe).
TP-1200 signal from 3-15 psi (0.2-1 Bar).

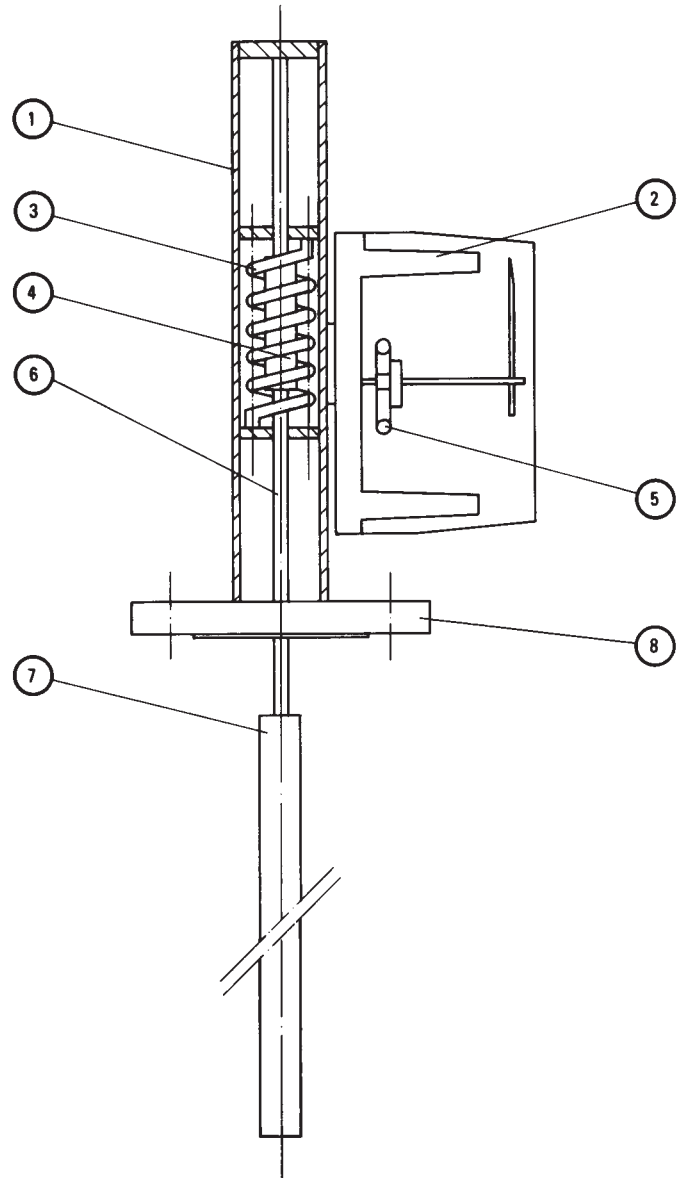

Construction

N°	Piece	Materials		
		LP-.../ SS	LP-.../ PVC	LP-.../ PTFE
1	Body	AISI-316	PVC	PTFE
2	Enclosure	Aluminium	Aluminium	Aluminium
3	* Spring	AISI-316	AISI-316	AISI-316
4	Float Magnet	Supernialco	Supernialco	Supernialco
5	Indicator Magnet	Supernialco	Supernialco	Supernialco
6	Float Guide	AISI-316	PVC	PTFE
7	Float	AISI-316	PVC	PTFE
8	Union	AISI-316	PVC	PTFE

* Others available on request

Dimensions series:

LP-80

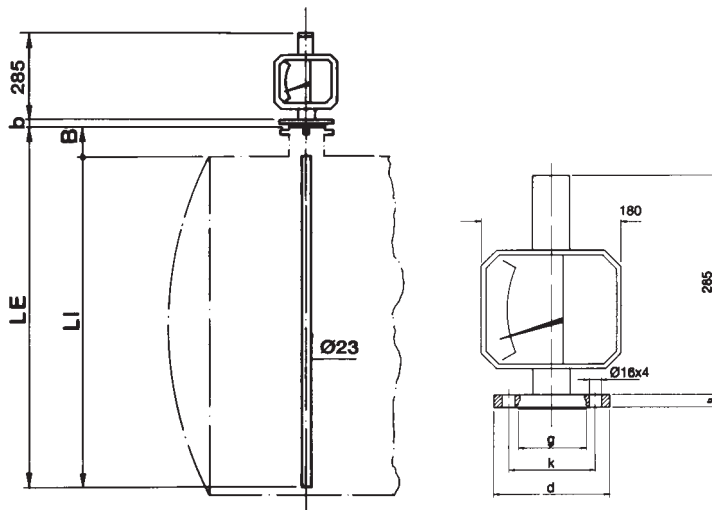

LP-80ME

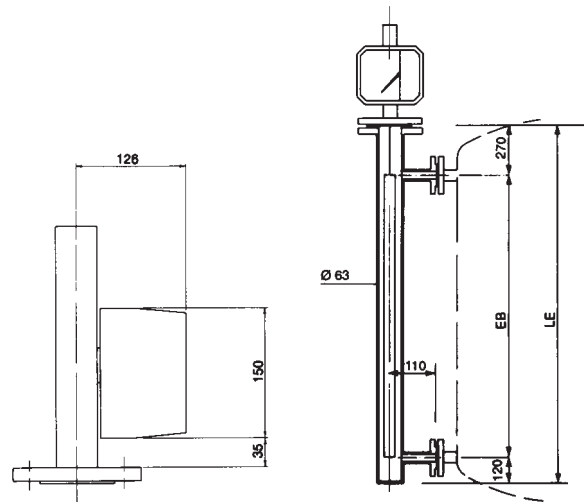

LP-81

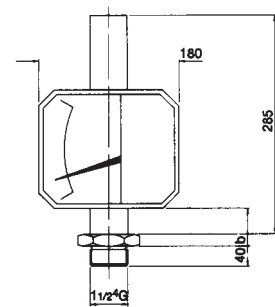

Series LP-80 and 80ME

DN	PN	D	k	g	lxn°	b	B	EB	LE	LI
40	40	150	110	88	18X4	18		an indicator		

Alarm Options

Adjustable Micro Alarm, Series LP-AMM

Micro-switch bi-stable contact mounted in the indicator enclosure of the level gauge.

- LP-AMM1: 1 adjustable alarm contact.
- LP-AMM2: 2 adjustable alarm contacts.
- Load: 3 Amp @ 220Vac/50Hz.
- Temperature: -25°C to +80°C.
- Hysteresis: ±10% of full scale.
- Mechanical life: 20 x 10⁶ Operations.
- Contact speed: 0.01 to 1 mSec.

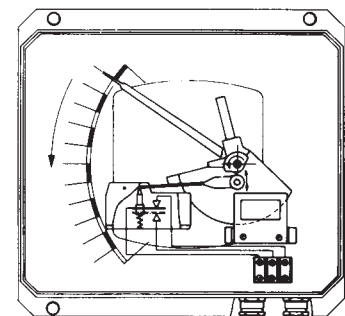

Adjustable Inductive Alarm, Series LP-AMD

Inductive proximity sensor, 3.5 mm, according to standard NAMUR DIN 19234, mounted in the indicator enclosure of the level gauge.

- LP-AMD1...2: 1 ... 2 adjustable alarm contacts.
(+ amplifier WE77/Ex1 or Ex2).
- Power Supply: 8 Vdc.
- Temperature: -25°C to +70°C.

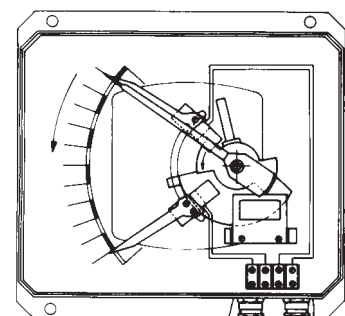



Transmitters

Electric Transmitter LP-TEH

Halltec Transducer based on a Hall effect pickup with zero friction on the indicating mechanism.

Output signal directly proportional to the measured flow rate.

- Accuracy: 1,5% of the reading value
- Analog output available: 0...4-20 mA
0-5V, 0-10V, 1-5V, 2-10V
- Power supplies: 24, 110, 220, 240 Vac, 50/60 Hz
24 Vdc
- Power consumption: < 3w
- Ambient Temperature: -10°C to + 60°C
- Electric connection: 4 wires

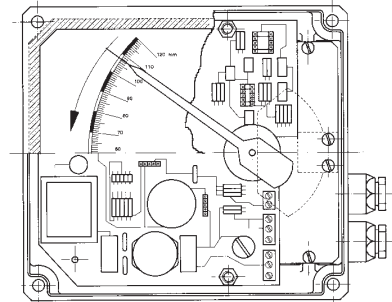

Electric Transmitter LP-TK-Ex

The electric transmitter TK-Ex is a two wire angular position converter. It provides a 4-20 mA output signal directly proportional to the measured level. Certified intrinsically safe to Cenelec EExib IIC T5/T6.

- Power supply: 12.7 to 36Vdc
- Load: 4 mA + Output current
- Output signal: 4-20 mA
- Electrical connection: 2 wire
- Internal capacitance: $C_p < 15F$
- Ambient temperature: EEx ib CT4 70°C Max
CT5 65°C Max
CT6 50°C Max

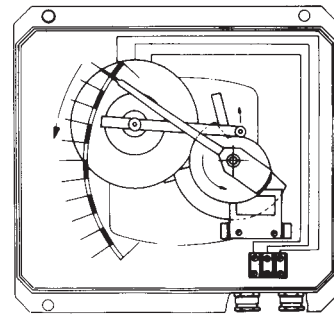

Pneumatic Transmitter LP-TP1200

The pneumatic transmitter SC-TP1200 provides a 3-15 psi or 0.2-1Bar pneumatic signal directly proportional to the measured flow rate.

- Air supply: Air 1.4 Bar \pm 0.1 Bar
- Consumption: 460 NI/h Air
- Output signal: 3-15psi (0.2-1Bar on request)
- Linearity: \pm 0.4%
- Hysteresis: \pm 0.25%
- Temperature: \pm 10°C to 70°C

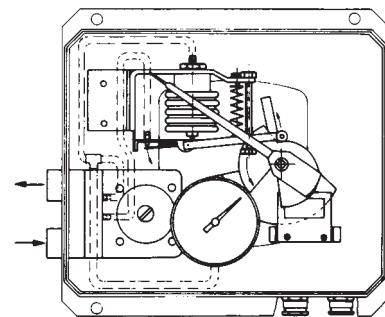

We are at your service, please consult us.
TECFLUID develops and manufactures instruments for gases and liquids, using the most advanced techniques.
Request Information by telephone n° 01 34 64 38 00



B.P. 27709 95046 CERGY PONTOISE CEDEX (FRANCE)
Tél. 01 34 64 38 00 – Fax. 01 30 37 96 86 Internet : www.tecfluid.fr