



Instructions Manual



The AMD limit switch consists of a NAMUR slot type inductive sensor, that is actuated by a vane. Given that there is no physical contact in the operation, the limit switch has no influence on the indicator needle movement. A NAMUR amplifier with a relay output can be supplied as an optional element.

OPERATION

The indicator needle moves together with the vane mounted on its shaft. When the vane enters into the slot of the detector, the limit switch changes its state.

The detector, is mounted on a support which includes an indicator on the scale, that shows the switching position. This support is guided by the scale plate slot.

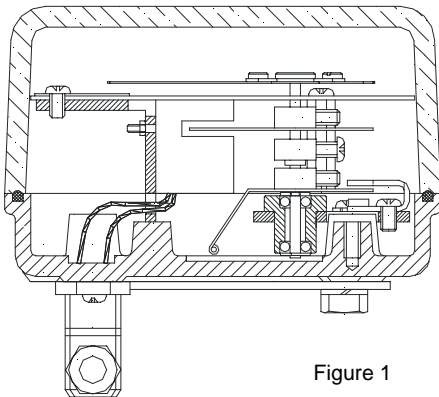
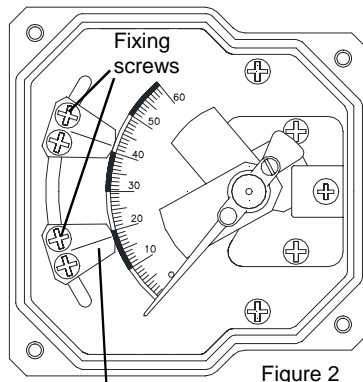

Figure 1



Limit switch indicator

SWITCHING POINT ADJUSTMENT

To gain access to the limit switch inside the indicator housing, remove the front cover held by four M4 x 8 DIN 7985 (Philips) screws.

To move the limit switch indicator, the fixing screws have to be slightly loosen (figure 2). After that, place the limit switch indicator in the required scale value, and fix it with the two screws.

As standard, when the instrument has only one AMD, it comes configured as a minimum limit switch. In the case of two AMD, one of them is for minimum and the other is for maximum. To change the standard configuration, refer to MAINTENANCE section.

ELECTRICAL CONNECTION

For the electrical connection, the instrument is provided with a for terminal connector.

Before starting the installation, check that the cable gland of the connector (PG7) is the right size for the cable to be used, this will guarantee the instrument will stay watertight (it is recommended to use multiple conductor cables with external diameter sections from 4 to 7.5 mm, with individual cable sections in the order of 0.25 mm²). Loose cables should not be used given that they can affect the seal of the cable glands.

Before wiring, disassemble the connector, removing the head, and unscrewing the cable gland. Remove the rubber seal and the washer.

After that, slide de cable through the cable gland nut, through the washer, through the rubber seal and finally through the connector head.

Strip the outside insulation of each conductor to free the inner wires so that once they are soldered in, the end of the outside insulation of the cable will just pass through the cable gland. It is recommended to tin the ends of the wires to avoid loose ends. Solder the two wires as shown in the figure of the following page.

Before assembling the connector, make sure that the position is such that the cable comes out at the bottom). After that, tighten up the cable glands so that they maintain their degree of protection.

In some instruments such as some models of ADI series, instead of having a connector, there is a cable gland with a cable with three colours (brown, blue and green/yellow). In this case the connections should be made as follows:

- Green/yellow = Earth
- Brown = +
- Blue = -

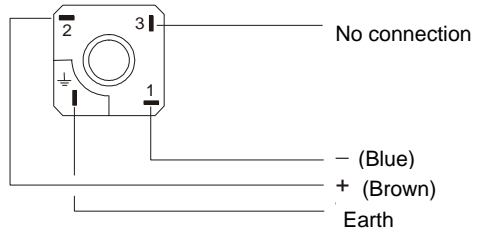

MAINTENANCE

1. Change of the vane position respect the limit switch

AMD-MAXIMUM

Place the limit switch indicator in the required scale value, fixing it by means of the 2 screws. After that, move manually the shaft that supports the indicator needle, until the indicator needle coincides with the maximum limit switch indicator. After that, loosen the grub screw (1.5 mm Allen key) of the vane and make point 1 coincide with the centre of the detector (Figure 3).

Tighten the screw to fix the vane.

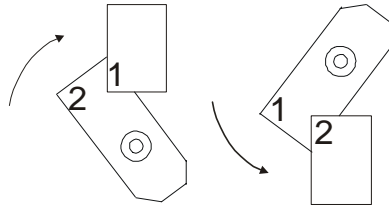

Figure 3

Figure 4

AMD-MINIMUM

The process is the same as for the maximum point, but making the point 2 coincide with the centre of the detector (Figure 4).

In the event that the instrument has two limit switches, the working range will be limited to the following values:

- From 0 to 25% of the scale, for the AMD of the minimum limit switch.
- From 75 to 100% of the scale, for the AMD of the maximum limit switch.

2. Electrical verification of the limit switch

- a) Check that the voltage at the terminals 1 and 2 is over 7.5 V when the vane is in the slot. Connect a multimeter with the scale in DC mA, in series with the terminal 2.
- b) Verify that the current is less than 1 mA when the vane is in the slot, and more than 3 mA when the vane is out of the slot.

If you don't have the NAMUR amplifier, the current can be checked using the following circuit diagram:

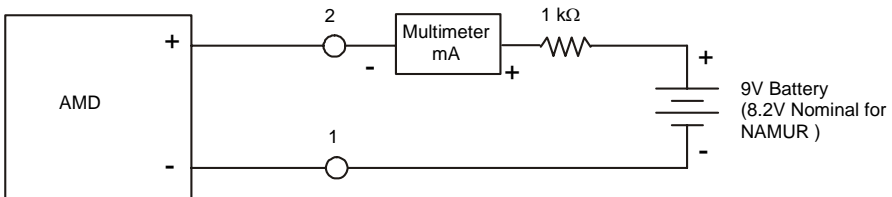

If you don't have the detector, the operation of the amplifier can be checked using the following circuit diagram:

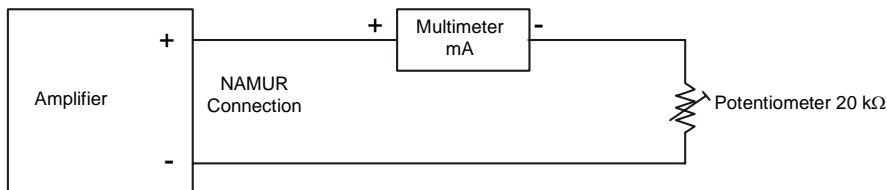

With the potentiometer we modify the current of the NAMUR amplifier. The switching point must be between 1.2 mA and 2.1 mA. That is, with the current below 1.2 mA the output relay must have a state and above 2.1 mA the output relay must have the other state.

TECHNICAL CHARACTERISTICS

The AMD is a NAMUR (DIN 19234) sensor with the following nominal characteristics:

Nominal voltage	8.2 V
Power supply internal resistance	1 kΩ
Current with the vane into the slot	< 1 mA
Current with the vane out of the slot	≥ 3 mA

Power supply limits	5 ... 25 VDC
Ambient Temperature	-25 ... +100 °C
Self inductance	160 μH
Self capacity	20 nF

Conforms with the Directive EMC 89/336/EEC



WARRANTY

Tecfluid S.A. GUARANTEES ALL ITS PRODUCTS FOR A PERIOD OF 24 MONTHS, after consignment, against all defects in materials and workmanship.

This warranty does not cover failures which can be imputed to misuse, use in an application different to that specified in the order, the result of service or modification by un-authorized persons, bad handling or accident.

This warranty is limited to cover the repair or replacement defective parts which have not been damaged by misuse.

This warranty is limited to the repair of the equipment and all further and eventually following damages are not covered by this warranty.

Any consignment of equipment to our factory or distributor must be previously authorised. The consignment should be done with the equipment well packed, clean of any liquids, grease or hazardous materials. Tecfluid S.A. will not accept any responsibility for damage done during transport.

Together with the equipment, a note should be enclosed indicating the failure observed, the name, address and telephone number of the sender.

TECFLUID
B.P. 27709
95046 CERGY PONTOISE CEDEX (FRANCE)
Tél. 01 34 64 38 00 – Fax. 01 30 37 96 86

Internet: www.tecfluid.fr

Dans un souci constant d'amélioration, les caractéristiques données dans nos notices techniques peuvent être changées sans préavis.