



Instructions Manual



The AMM limit switch consists of a micro-switch driven by a an eccentric cam mounted on the indicating needle.

ADJUSTING THE SWITCHING POINT

To gain access to the limit switch inside the indicator housing, remove the front cover held by four M5 x 16 DIN 912 screws, using a 4 mm Allen key.

To gain access to the electrical terminal block, remove the data plate held by two M3 x 4 DIN 7985 (Philips) screws.

With the indicating needle at the zero point of the scale, the cam should always be acting on the micro-switch lever. With two limit switches the cams should act on both micro-switch levers.

To adjust the switching point, loosen the cam's grub screw (C) with a 1.5 mm Allen key, and turn the cam on the needle shaft until the required switching point is achieved.

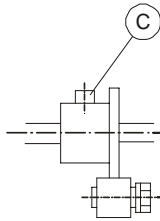

To turn the cam on the shaft, do not hold the shaft by the indicating needle, as this may move the needle on the shaft. The shaft should be held directly.

For the SC, SM, LP and DP DES series, if the cam is turned in the "A" direction, the acting point will move towards the zero point of the scale. If the cam is turned in the "B" direction, the acting point will move away from zero the point of the scale.

For the DP ED, DP DAB and DP BD series, if the cam is turned in the "A" direction, the acting point will move away from the zero point of the scale. If the cam is turned in the "B" direction, the acting point will move towards the zero point of the scale.

Once the cam is in its position and the grub screw (C) has been tightened, the correct working of the limit switch should be verified by turning the indicating needle shaft and checking the switching at the required point.

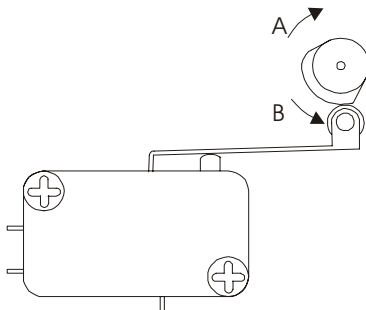

Cam shown acting on the micro-switch lever as it should be at the zero of the scale.

ELECTRICAL CONNECTION

For the electrical installation it is recommended to use multiple conductor cables with individual cable sections in the order of 0.25 to 0.5 mm² in order to make it easier to connect. Loose cables should not be used given that they can affect the seal of the cable glands. It is better to maintain the cables with mains voltage separated from the cables with low level signals.

Before starting the installation, check that the cable glands are the right size for the cables to be used, this will guarantee the instrument will stay watertight.

Peel the outside insulation to free the inner cables. It is recommended to tin the ends of the wires to avoid loose ends.

Next, feed the cables through the cable glands, and connect to the corresponding screw terminals.

Last, tighten up the cable glands so that they maintain their degree of protection (IP).

The numbering of the terminals is given on the printed circuit board.

 Earth.

Terminals marked "A" for one limit switch or for the bottom limit switch.

A3 - Normally Open

A2 - Normally Closed

A1 - Common

Terminals marked "B" for the top limit switch.

B3 - Normally Open

B2 - Normally Closed

B1 - Common

NOTE : The contacts are defined for zero flow rate (cam acting on the micro-switch lever)

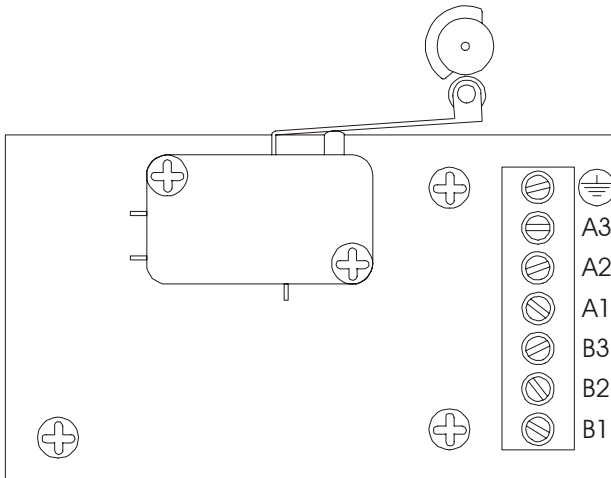

Cam shown in position
when NOT acting on micro-
switch lever

TECHNICAL CHARACTERISTICS

Maximum switching current 3 A
Maximum switching voltage 250 Vac

Potential free SPDT contacts

Conforms to the 73 / 23 / EEC Directive



WARRANTY

Tecfluid S.A. GUARANTEES ALL ITS PRODUCTS FOR A PERIOD OF 24 MONTHS, after consignment, against all defects in materials and workmanship.

This warranty does not cover failures which can be imputed to misuse, use in an application different to that specified in the order, the result of service or modification by un-authorized persons, bad handling or accident.

This warranty is limited to cover the repair or replacement defective parts which have not been damaged by misuse.

This warranty is limited to the repair of the equipment and all further and eventually following damages are not covered by this warranty.

Any consignment of equipment to our factory or distributor must be previously authorised. The consignment should be done with the equipment well packed, clean of any liquids, grease or hazardous materials. Tecfluid S.A. will not accept any responsibility for damage done during transport.

Together with the equipment, a note should be enclosed indicating the failure observed, the name, address and telephone number of the sender.

TECFLUID
B.P. 27709
95046 CERGY PONTOISE CEDEX (FRANCE)
Tél. 01 34 64 38 00 – Fax. 01 30 37 96 86
Internet : www.tecfluid.fr