



## Users Manual



## Technical Data

- Precision:  $\pm 0,8 \%$ .
- Repeatability:  $\pm 0,3\%$ .
- Rangeability: 30:1.
- Mounting: Horizontal or vertical.
- Pipe fittings: DIN 2501 PN 16 Flanges.  
Others on demand.
- Materials: AISI-316, PVC, PTFE, PP.
- Working Pressure:
  - AISI-316: PN 16
  - PVC / PTFE / PP: PN 10
  - Others on demand.
- Working temperature:
  - Standard:
    - AISI-316:  $-40^{\circ}\text{C}...+150^{\circ}\text{C}$ .
    - PVC:  $0^{\circ}\text{C}...+40^{\circ}\text{C}$ .
    - PTFE:  $-20^{\circ}\text{C}...+130^{\circ}\text{C}$ .
    - PP:  $-10^{\circ}\text{C}...+80^{\circ}\text{C}$ .
- Piston material: PTFE-Graphite, Aluminium, Bronze.
- Connector IP-65. On demand EExd terminal box.
- Recommended cable: bifilar with shield over 50 m length.

- Complies with 97/23/CE Directive for pressure vessels.

CE 0830



This equipment is considered as being a pressure accessory and **NOT** a safety accessory as defined in the 97/23/CEE directive, Article 1, paragraph 2.1.3.

- Auxiliary Electronics:
  - CIP:
    - Battery powered volumetric counter.
  - MC-01:
    - Flow rate and volume indicator with batching pre-selection.
  - MT-02:
    - Volume counter with batching pre-selection..
  - DFD-2:
    - Frequency divider for control instruments.
  - CI-420:
    - Analog transmitter for control instruments.

For more information consult the specific catalogues.

## Working principle

Via rotary oscillating piston and annular metering chamber.

The drawings show the rotation of the piston, moved by the fluid flow through the metering chamber.

Inside the piston there is a magnet that drives an external reed switch once every complete cycle. The signal from the reed switch is the input to electronic counters.

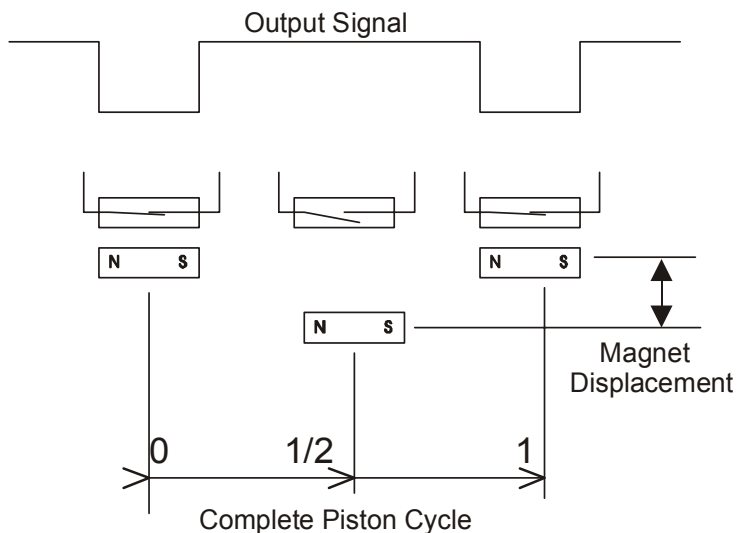

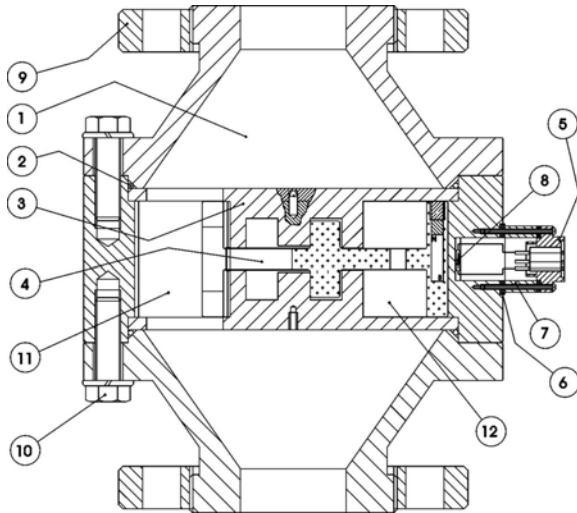

N°	Pieza	AISI-316	PTFE	PVC / PP
1	Input/Output Chamber	AISI-316	PTFE	PVC / PP
2	O-ring	Acrylonitrile / Viton®	Viton® / PTFE	Acrylonitrile/ Viton®
3	Guide disk	AISI-316	PTFE	PVC / PP
4	Piston	PTFE-Graphite, Al, etc	PTFE-Graphite	PTFE-Graphite
5	Connector	Brass / Plastic	Brass / Plastic	Brass / Plastic
6	Flat gasket	Acrylonitrile	Acrylonitrile	Acrylonitrile
7	Separator	AISI-316	AISI-316 / PTFE	AISI-316 / PVC / PP
8	Reed Switch	Glass 0,3 A-220V	Glass 0,3 A-220V	Glass 0,3 A-220V
9	Flanges	Steel/ AISI-316	Steel/ PTFE	Steel-PVC / PP
10	Screws	AISI-304	AISI-304	AISI-304
11	Input/Output separator	AISI-316	PTFE	PTFE
12	Metering chamber	AISI-316	PTFE	PVC / PP

## OPERATION

### Position 1

The flow of a liquid through the COVOL volumetric counter exercises a pressure on the piston which starts the metering movement. In this position the liquid starts to fill the inside of the piston.

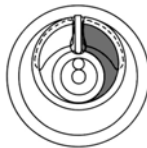

### Position 2

The entry of liquid fills progressively the space between the counter's chamber and the piston and continues to fill the inside of the piston.



### Position 3

In this point the inside of the piston has been completely filled and the outside chamber continues to be filled.

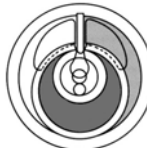

### Position 4

The inside of the piston starts to empty. The outside chamber continues to be filled. Also the inside of the piston starts to be filled again.



From this point the piston repeats the cycle, moving a CONSTANT VOLUME of liquid for each cycle, progressively opening and closing the inlet and outlet of the metering chamber.

## Dimensions

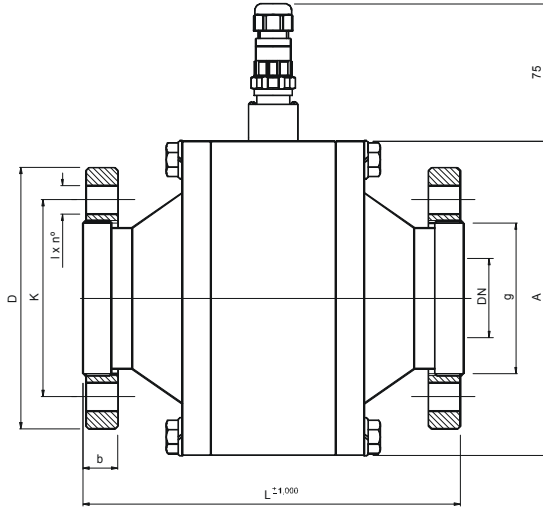

### AISI-316

DN	D	k	g	l x n°	B	Flange PN	A	L
10	90	60	40	14 x 4	14	16	85	180
15	95	65	45	14 x 4	14	16	105	180
25	115	85	68	14 x 4	16	16	140	200
40	150	110	88	18 x 4	16	16	180	220
50	165	125	102	18 x 4	18	16	200	240
80	200	160	138	18 x 8	20	16	250	260
100	220	180	158	18 x 8	20	16	360	340

### PVC, PTFE, PP

DN	D	k	g	l x n°	B	Flange PN	A	L
10	90	60	40	14 x 4	14	10	125	210
15	95	65	45	14 x 4	14	10	140	210
25	115	85	68	14 x 4	16	10	170	230
40	150	110	88	18 x 4	16	10	200	250
50	165	125	102	18 x 4	18	10	230	270
80	200	160	138	18 x 8	20	10	290	330
100	220	180	158	18 x 8	20	10	420	450

## RECEPTION

COVOL volumetric counters are supplied individually packed for protection during transport and storage.

All auxiliary equipment that may be ordered is supplied in the same conditions.

All equipment has been tested and is ready to use once it is mounted and wired according to these instructions.

## INSTALLATION

### Mechanical installation

1. It does not need straight sections of pipe and can be installed immediately before or after regulation or fast closing valves.
2. The position of the counter can be indistinctly vertical or horizontal or inclined.  
The flow direction does not have any influence on the precision of the COVOL.
3. You must always be sure that the pipes are full of liquid and free of air.  
If there is any possibility of an air intake in the installation, an air extractor should be installed before the counter.

**A FILTER MUST BE INSTALLED** before the COVOL to guarantee correct working and avoid expensive damage.

The mesh filter should have 0,1 to 0,2 mm<sup>2</sup> pitch to avoid big particles that may block or encrust in the rotating piston and act as a break by rubbing, producing errors in the flow or volume readings.

### Electrical Installation

The COVOL counter has a detector for the rotary piston, which closes an electrical contact once for every revolution of the piston.

The external part of the detector is fastened to the counter by 4 screws. The connector consists of 3 parts joined by threaded nuts. (Fig. N° 1).

Loosening the larger nut in the middle of the connector allows us to withdraw the half where later the cable will be soldered.

The other half of the connector is fixed to the counter and should not be removed, except when servicing the detector (See part 3 of the maintenance section).

The part of the connector we have removed consists of the cable gland at the top and the electrical connection protector housing.

The electrical connection protector housing is dismantled by loosening the second nut.

When this is removed, the three connector terminals are visible.

The terminals are numbered 1 to 3 and the connection is as follows:

- N° 1 & 2 : Electrical switch connection.  
N° 3 : No connection.

Before soldering the connections, unscrew the cable gland and feed it, together with the electrical connection protector housing, over the cable.

The joint between the cable and the connector should always be soldered, and should be tidy and without short circuits between terminals.

Once the connections have been made, the housing should be mounted screwing it on and then the cable gland should be tightened to avoid entry of any liquid or humidity.

Once assembled the half of the connector, the mounting in the base has ONLY ONE POSITION defined by the keyway between the two parts.

Check that the rubber seal is in its position inside the connector base. If this is the case, introduce the connector half in the base, positioning by the keyway, and screw on the nut until the end of the thread is reached.

IT IS IMPORTANT THAT THE INSTALLATION OF THE CABLE BETWEEN THE COVOL COUNTER AND THE ELECTRONIC COUNTERS IS MADE IN ZONES WHERE THERE ARE NO HIGH VOLTAGE OR POWER CABLES.

In the event that these cables are present, the flow meter cable should be kept at least 5 cm away from them.

## OPERATION

### Mechanical Part

1. The oscillating rotating piston of COVOL's mechanic system, allows volume readings with better than  $\pm 0,5\%$  precision in correct installations.

Each piston revolution inside the metering chamber, transmits a constant volume depending of the characteristics of the fluid, for water at 20°C, average data is:

Table 1

DN	Pulses / Litre $\pm 15 \%$	cm <sup>3</sup> / Pulse $\pm 15 \%$
10	100	10
15 ( special )	50	20
15	20	50
25	10	100
40	4	250
50	2	500
80	1	1000
100	0,2	5000

### RECOMMENDED OPERATION MAXIMUM/MINIMUM FLOW RATE

Table 2

DN	MINIMUM FLOW RATE l / h	MAXIMUM FLOW RATE m <sup>3</sup> /h	MAXIMUM INTERMITTENT FLOW RATE m <sup>3</sup> /h
10	8	0,150	0,5
15 ( special )	25	0,4	0,8
15	60	1,5	2,7
25	80	4,5	9
40	120	8,5	15,5
50	180	16	28
80	380	28	50
100	500	60	104

The pressure drop at maximum flow rate for all models is 3 m H<sub>2</sub>O (0,3 bar).

2. INSTALLATION OBSERVATIONS. The high repeatability of volumetric transmission for each piston revolution can be affected by incorrect installation. The following are the consequences of bad installation and the cause.

– OBSTRUCTION OR FRICTION OF THE PISTON BY PARTICLES

Normally caused by the absence of a filter or perhaps the mesh size is bigger than the recommended ( 0,1 to 0,2 mm<sup>2</sup> ).

– AIR POCKETS. THE COUNT IS HIGHER THAN REAL VOLUME.

Excessive emptying of storage tanks, the minimum level should be controlled.

Provide venting in cases of possible air inlets. These should be mounted before the counter.

– CAVITATIONS

Avoid the installation of a COVOL COUNTER in low pressure zones, for example in suction side of pumps or in down-flowing discharge pipes with a free outlet.

In these cases, the air pockets that can reach the counter, due to inadequate pipe installation or those formed by cavitations, will not exit the counter.

For the correct working of COVOL counters, one should follow the API 2534 norm which states that at the outlet of counters there should be a PRESSURE HIGHER THAN TWICE THE COUNTER PRESSURE DROP (COVOL counter 3 m. H<sub>2</sub>O at maximum flow rate), plus 1.25 TIMES THE VAPOUR PRESSURE OF THE LIQUID OR ITS MOST VOLATILE COMPONENT.

– VOLUME VARIATION

Pipe lengths that behave in different ways in each filling operation of reactors or open tanks.

One must make sure that the pipes always work as a FULL pipe or an EMPTY pipe.

*EMPTY pipe.* The continuity of the pipe is broken after the counter by use of a funnel and posterior discharge pipe.

*FULL pipe.* The discharge pipe is above the level of the counter.

By means of a fast closing valve installed at the outlet of the discharge pipe.

This possibility is valid only when ONLY ONE product is measured

When is necessary to count several products using ONLY ONE COUNTER, fast closing valves must be installed in each pipe, just before the collector inlet.

It is important to take into account all the conditions we have indicated for EMPTY pipes, CAVITATIONS or AIR POCKETS.

It is recommended to use the last product as the cleaning element of counter.

## Electrical part

3. THE REED OR DETECTOR of the rotating piston revolutions is mounted exteriorly in the central ring of COVOL counter body.

The maximum working temperature is 130°C, on special order up to 150°C.

It is fixed by 4 screws to the counter body and exteriorly consists of the cable connector, the connector base, the rubber glands and the separator. On the inside it has a terminal block and a reed switch.

The cable connector, as explained previously, can be dismantled using the larger nut to separate it from the base.

The rest of the assembly is dismantled by loosening the 4 M-3 screws and removing it from the counter body.

It is advisable to remove the complete assembly, including the rubber seals, all at once, given that the seals can obstruct the pass of the reed switch and break it.

In the event of breakage of the reed switch, it can be changed by loosening the lower screws of the terminal block.

The reed switch is mounted by introducing the two connections, one in each terminal of the terminal block and tightening the screws.

The mounting of the reed switch on the counter should be done as shown in Fig 1, taking into account THE POSITION OF THE REED SWITCH IN THE GROOVE, located in the bottom of the housing.

It is also important that the space between the reed switch and the body of the flow meter is not greater than 2 mm, as shown in Fig 1, otherwise the reed switch may not be activated by the magnet in the interior piston.

Also the reed switch should not touch the flow meter body because the reed switch could break when the assembly is tightened.

**NOTE:** When the counter is made of plastic ( PTFE, PP, PVC. etc.) The reed switch assembly has no separator and there is only one rubber seal.

Taking into account the previous, the mounting of the assembly is made by assembling the pieces and positioning it in the seating in the body. The assembly is fixed by the 4 M-3 screws, tightened until the resistance of the seal is noted.

## MAINTENANCE

In normal working conditions the COVOL counter has a long life. Normally it will not be necessary to change any parts.

The life of the parts depends mainly on the abrasive characteristics of the product to be measured and the flow rate.

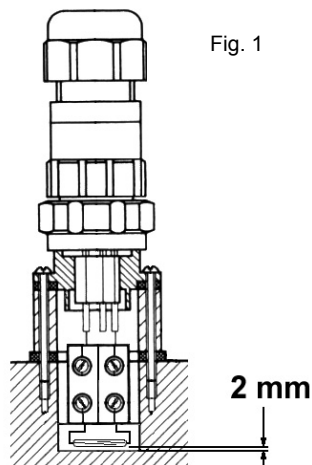

The combination of these two factors, together with the construction material of the counter, make it difficult to estimate the life of the counter in good working conditions

**NOTE:** If the maximum flow rate for each DN shown in Table 2 is exceeded the life of the pieces can be considerably reduced.

The maintenance of the COVOL counter in normal installations in good conditions is practically null due to the simple construction.

### 1. DISASSEMBLY

The equipment consists of the following elements:

- THREADED PIPE FITTINGS OR FLANGES (CUPS)
- COUNTER BODY (Central body and Input/Output Chamber )
- ROTARY PISTON
- PRODUCT INPUT/OUTPUT SEPARATOR
- METERING CHAMBER GUIDE DISK (TWO)

## THREADED PIPE FITTINGS OR FLANGES (CUPS)

The threaded pipe fittings or flanges (cups), do not require any type of maintenance except routinary cleaning.

### *COUNTER BODY.*

The central ring of the counter is the metering chamber in which the rotary piston turns, moving a constant volume for each cycle.

It can only be deteriorated by abrasive products, or unfiltered hard particles, that scratch the inside wall of the metering chamber, or incrust in the piston.

If the effect is important, the metering chamber must be touched up in out workshops and then adjusted with a new rotary piston.

The disassembly of the body should be started at the side marked with the number 2, and this is done by loosening the hexagonal bolts situated on the periphery of the cups and central ring of the counter.

Once loosened and removed (it only has to be done on the N° 2 side of the counter), we can detach the cup. The O ring and the smooth exterior part of the metering chamber's disk can now be seen.

The disk has a threaded hole that takes a screw to allow us to withdraw the disk smoothly.

The disk should be withdrawn perpendicularly, uncovering the metering chamber with the rotary piston and input/outlet separator.

The piston is easily removed and it has a drop form opening into which the input/outlet separator is fitted which acts as guide for the rotation of the piston.

The input/outlet separator joins the metering chamber ring to the central circular guide of the guide disk.

It is extracted by pulling it out perpendicularly.

In this way the metering chamber is completely dismantled for inspection and thorough cleaning if necessary

### *ROTARY PISTON*

This is the only mobile piece of the COVOL counter.

It has a long life due to the Teflon and graphite composition, that makes it very wear resistant and gives it a low friction coefficient.

Premature wear can only be due to abrasive products and flow rate higher than those indicated in Table 2, which provoke excessive knocks at the inflection point of the oscillating turning of the piston, producing breakage at very high speeds.

## **2. MOUNTING AND MAINTENANCE.**

- a. If the counter body has been completely dismantled, reassembly should start with the cup N° 1. For this, one cup, the corresponding O ring and the guide disk, with the body rings towards the inside of the metering chamber, starting with the number 1.

The counter body (central ring) is assembled and the fixing screws are mounted around the edge, they are tightened until a rigid assembly is obtained (the final tightening will be done later).

The input/output separator is fitted with the bevelled part in the groove of the guide disk rings and the part with sharp edges in the groove of counter ring.

- b. The piston is mounted taking care that the drop form opening fits over the input/output separator and that the piston shaft fits into the circular groove formed by the two rings of the guide disk. Check that the piston rotates smoothly without rubbing in its complete path.
- c. With the help of the extractor screw that we have mounted during disassembly, mount the guide disk with the flat side outwards, coupling the key seat in its position.

Note that the guide disk N° 2 HAS IT'S MOUNTING POSITION DEFINED by the groove for the input/output separator (on N° 1 side the guide disk is positioned by a hole that fits over a pin).

These two elements indicate the mounting position which should be made to coincide exactly.

If this is not done as indicated, the guide disk could deteriorate and also a hermetic seal of the counter will not be obtained.

- d. Check the perfect fitting of the guide disk, place the O ring on the guide disk and adjust it around the edge of the counter ring.
- e. Mount the cup or coupling piece, checking the position of the O ring. Assemble the fixing screws and tighten them until the two pieces are firmly against each other.

Tighten the screws of the other cup.

The counter is ready for installation and operation.

#### **MAXIMUM WORKING CONDITIONS**

V max: 30 Vdc.      I max: 20 mA.

APPLICATIONS

Filling tanks

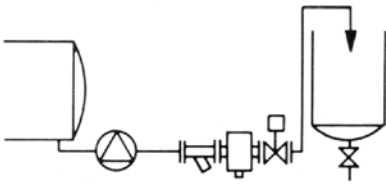

Volume batching

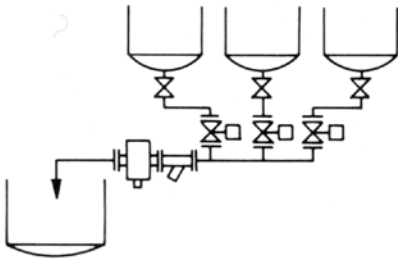

Measuring condensed vapour and fuel consumption

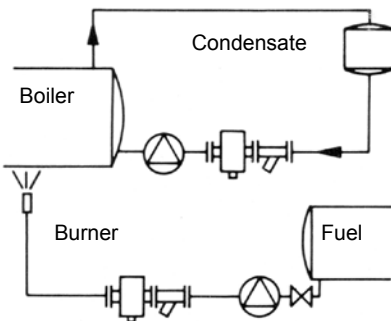

MOUNTING

Counter and electro valve in the working area

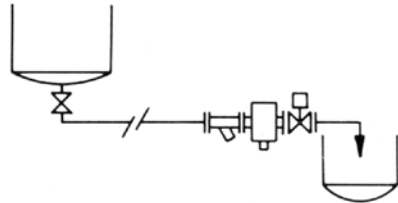

Counter in storage area and electro valve in working area

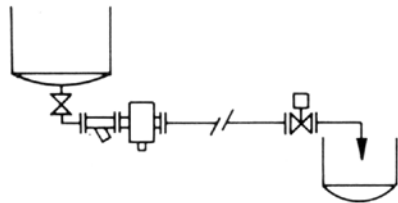

Closed Valve

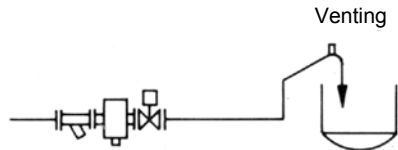

Venting

Open Valve

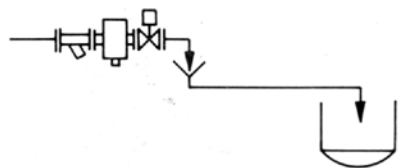

## **WARRANTY**

Tecfluid S.A. GUARANTEES ALL ITS PRODUCTS FOR A PERIOD OF 12 MONTHS, maximum 18 months after consignment, against all defects in materials and workmanship.

This warranty does not cover failures which can be imputed to misuse, use in an application different to that specified in the order, the result of service or modification by un-authorized persons, bad handling or accident.

This warranty is limited to cover the repair or replacement defective parts which have not been damaged by misuse.

This warranty is limited to the repair of the equipment and all further and eventually following damages are not covered by this warranty.

In the event of consignment of equipment to our factory, this should be done with the equipment well packed and prepaid transport, clean of any liquids, grease or hazardous materials. Tecfluid S.A. will not accept any responsibility for damage done during transport. Together with the equipment, a note should be enclosed indicating the failure observed, the name, address and telephone number of the sender.

---

**TECFLUID**  
B.P. 27709  
95046 CERGY PONTOISE CEDEX (FRANCE)  
Tél. 01 34 64 38 00 – Fax. 01 30 37 96 86  
Internet : [www.tecfluid.fr](http://www.tecfluid.fr)