



Instruction Manual



Conforms with the Pressure Equipment Directive 97/23/EC.

CE 0830



This equipment is considered as being a pressure accessory and **NOT** a safety accessory as defined in the 97/23/EC directive, Article 1, paragraph 2.1.3.

WORKING PRINCIPLE

The Flomat electromagnetic insertion flowmeter, are based on Faraday's induction law.

When an electrically conductive liquid flows through a magnetic field, perpendicular to the flow direction, it induces a voltage E, proportional to the liquid velocity.

Two electrodes in contact with the liquid and positioned perpendicular to the magnetic field, sense this voltage E.

$$E = B \cdot v \cdot d$$

Where:

E = Measured voltage in the electrodes.

B = Magnetic flux density

v = Average liquid velocity

d = distance between electrodes

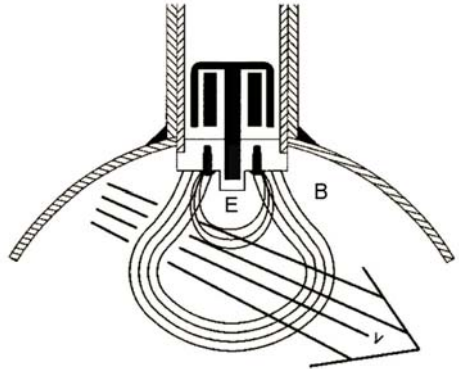

RECEPTION

The Flomat electromagnetic flowmeters are supplied conveniently packed for transportation together with the instruction manual for installation and service.

All the flowmeters have been tested in our calibration rigs to obtain the Fc factor for each sensor.

Unpacking

Carefully unpack the instrument, removing all packing material. Do not remove any grease from the collar that fits to the electronics housing.

Storage Temperature

-20°C +60°C

Handling

This should always be done with care and without knocks.

INSTALLATION

This should be made in a point that guarantees that the pipe is always completely full.

Avoid high points of the pipes where air pockets usually form, or pipes with falling flow where vacuums can form.

Partially full pipes can produce important reading errors.

Flow rate measurement with open discharge makes it necessary to install the flowmeter in a pipe section with a siphon which avoids stagnation of air in the sensor.

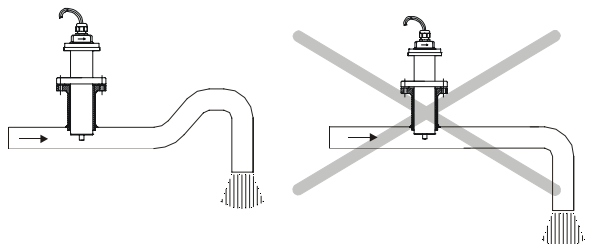

Sensor position

The most adequate position is in the side of the pipe. In this way, deposits of particles on the electrodes and air pockets at the top of the pipe are avoided.

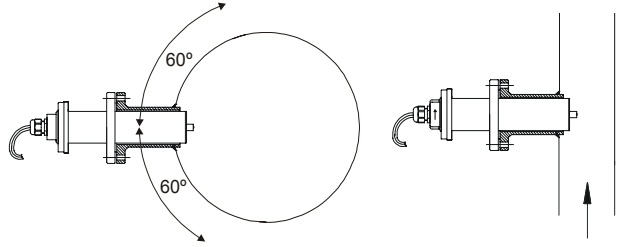

Straight pipe sections

Are necessary before and after the sensor. These should not contain any obstacles (valves etc.) The minimum distances are the following:

- Upstream : 10 DN
- Downstream : 5 DN

In installations with turbulent flow it may be necessary to increase these distances.

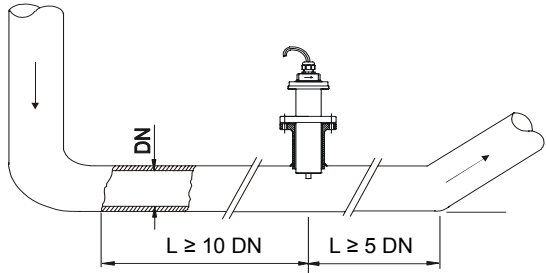

Mixtures

If liquids of different conductivities are mixed it is necessary to install the sensor a minimum of 30 DN from the point of mixture in order to obtain a uniform conductivity of the liquid and stabilize the readings.

If this distance is less, the readings may be unstable.

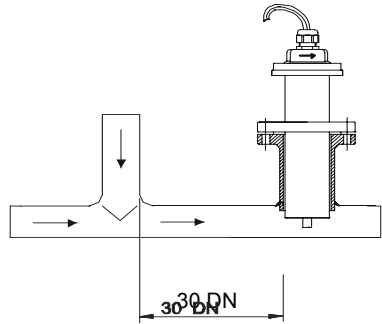

Control valves or stop cocks should always be installed downstream from the sensor to assure that the pipe is always full of liquid.

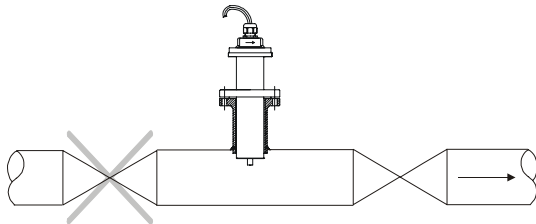

Pumps should be mounted upstream from the sensor to avoid the suction part of the pump (vacuum).

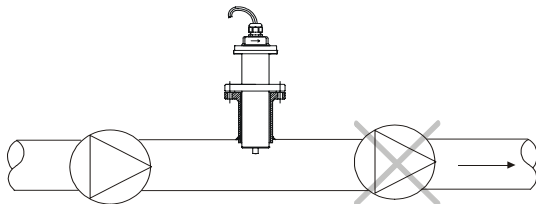

Vibrations

Vibrations of the pipes should be avoided by anchoring the pipe before and after the sensor.

The vibration level should be less than 2.2 g in the range of 20 -150 Hz according to IEC 068-2-34.

Temperature

In open air installations it is recommended to install a protection to avoid direct sun light on the flowmeter.

With thermally insulated pipes DO NOT insulate the sensor. High temperatures can damage it.

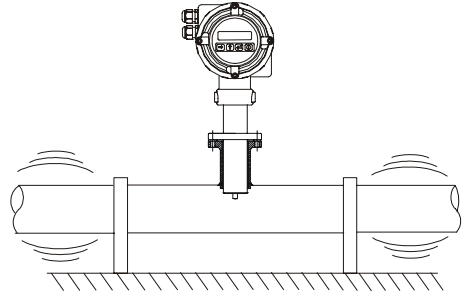

Magnetic fields

Strong magnetic fields close to the sensor should be avoided.

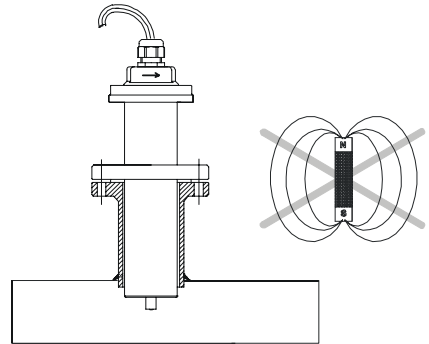
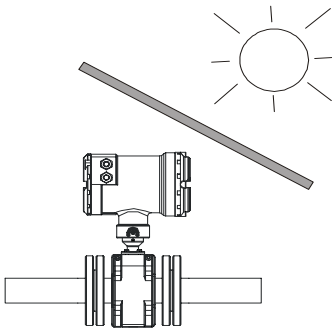

MOUNTING THE INSERTION FITTING

The sensor is normally supplied mounted in its insertion fitting. Before welding the fitting to the pipe, the sensor must be removed to avoid irreparable damage due to excessive temperatures.

There are two basic types of insertion fitting, threaded fitting and flange fitting.

For DN 40, 50 & 65 the insertion fitting is supplied fitted to a short length of pipe with a "T" form. For this type just couple it to the pipe by welding or gluing in the case of PVC.

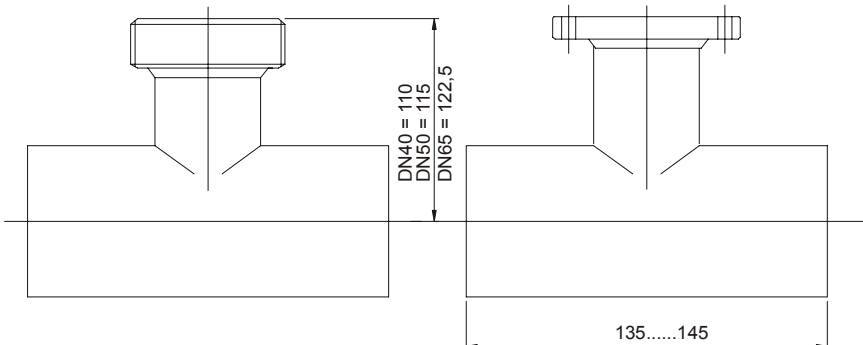

For DN greater than 65 mm for each of the two types of fittings there are three lengths.

DN	A Sensor Length	C	(H)	De	s	Insert Length	Qnom L/h
80	105	15	86	88.9	3.2	93	90.477
100		15	86	114.3	3.6		141.300
125		19	82	139.7	4		220893
150		22	78	168.3	4.5		318086
200		30	69	219.1	5.9		565.486
250		38	61	273.1	6.3		883.572
300		45	46	323.9	8		1.272.345
350		52	41	368	10		1.731.803
400		60	33	419	10		2.261.946
500	210	75	186	521	11.5	145	3.534.291
600		90	111	632	12		5.089.380
700		105	96	724	12		6.927.211
800		120	81	827	13.5		9.047.786
900		135	66	928	14		11.451.105
1000		150	51	1032	16		14.137.167
1200	360	180	180	1236	18	190	20.357.520
1400		210	150	1436	18		27.708.847
1600		240	120	1640	20		36.191.147
1800		270	90	1844	22		45.804.421
2000		300	60	2060	25		56.548.668

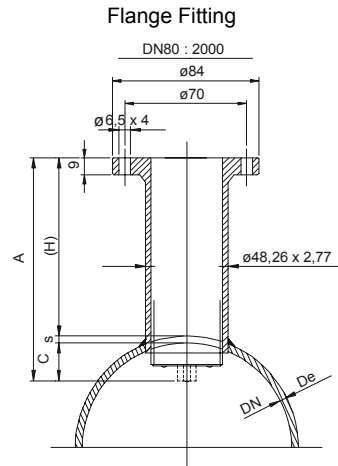
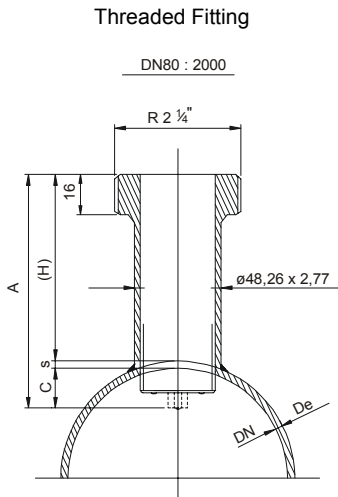

The measurements "De" & "s" are approximate given that they can vary with the working pressure and the type of material of the pipe

Drill a 48.5 mm diameter hole in the pipe to insert the fitting and weld the fitting to the pipe. If the pipe is of fiber cement or other material to which the insertion fitting cannot be welded, a collar fitting or saddle fitting should be used. These are easily available on the market.

To help to position the fitting in the pipe, on the side of the fitting there is a label with markings of the position of the internal pipe diameter for each DN. Cut this label above the corresponding DN marking at a distance equal to the pipe thickness. Peel off the bottom part of the label. Where the label was cut should coincide with the exterior of the pipe when it is welded.

When the insertion fitting is flange mounting type it is VERY IMPORTANT that the flange screw holes are aligned as in the following drawing.

If the flange is not perfectly aligned with the pipe this can give way to important measurement errors

The axis of the insertion fitting should be perfectly perpendicular to the pipe axis.

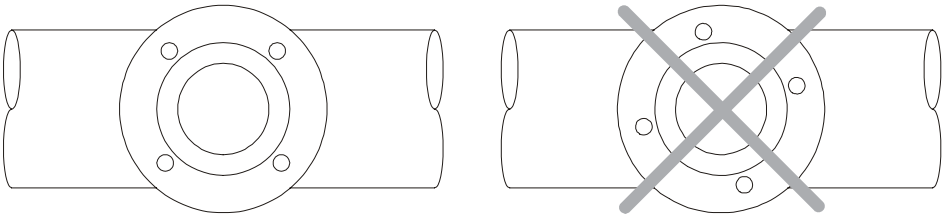

Once the insertion fitting is mounted, place the flat seal in its position and install the sensor with the arrow pointing in the flow direction. The electrodes must be perfectly perpendicular to the pipe axis.

Two variants of the sensor head exist:

The first variant has a flat face on each side with an engraved arrow which indicates the normal flow direction. This type of sensor can have a cable coming directly out of a cable gland for remote control units or can be screwed directly to a Flomat MC/T or MC/S electronics.

To mount this variant, the flat faces must be parallel to the pipe axis and the arrow pointing in the flow direction.

The second variant has a cylindrical head for adapting a cable with connectors for remote electronics or for coupling different electronics units directly on the head. For mounting this variant, the two studs (one on each side of the head) should be aligned with the pipes axis and the arrow on the adhesive label should be pointing in the flow direction. In the absence of the label, the studs have a “-” engraved on one and a “+” engraved on the other. The normal flow direction is from “-” to “+”.

Tightening Torque

The tightening torque for the flange screws should not exceed 7.1 Nm.

The tightening torque for the threaded fitting should not exceed 21 Nm.

Connecting (for sensors of the second variant)

In the event of having removed the electronics unit or cable from the sensor during installation, just reconnect the connectors to the sensor, push on the coupling on the sensor head and tighten the two lateral screws, and in the case of having a cable, tighten the cable gland to maintain the watertightness. In the event of a remote electronics, for the connection of the cable to the control unit, refer to the electronic units manual.

Configuration

Some electronics units are not configurable and these have been factory adjusted in our installations. In this case the equipment will be ready for service.

In the majority of cases it is necessary to configure the equipment to put the installation into service.

The Flomat sensor has been calibrated in our calibration rigs to determine the “Fc” factor. This factor corresponds to the signal level with a liquid speed of 5 m/s in the pipe. In order to give a correct flow rate reading, the electronic unit must be configured, introducing this factor (Fc) as well as the nominal flow rate that would flow in the pipe at a speed of 5 m/s (Qnom). The values of Qnom depend only on the pipe diameters and can be found in the table on page 5 for the majority of the standard pipe diameters.

POSSIBLE PROBLEMS WHEN COMMISSIONING

1. No flow rate signal.

Some instruments do not have automatic flow direction detection. Check that the flow direction in the pipe is the same as marked on the sensor. Check that the cables for remote electronic units have been correctly connected. Inverted coil cables or electrode cables will have the same effect as inverting flow direction.

Check that the electrodes are perpendicular to the flow direction. If the sensor is mounted with the electrodes aligned with the flow direction the output signal will be very poor and the flow rate reading could be zero.

Check that the electrodes are clean and free from grease. If the electrodes are dirty with grease or other insulating substance there will be no output signal. In this case some electronics units can indicate “empty pipe”.

Check that the pipe is completely full. (That the electrodes are fully covered with liquid).

2. The reading is not stable

Check that there are no obstacles or bends near the sensor, especially upstream that can produce important turbulences

Check that there are no air bubbles or solids that interrupt the conduction path between the electrodes producing instability in the signal level

In the control units that have a configurable filter, in most cases a stable reading can be obtained by means of the filter configuration. The filters have two characteristics that govern their operation:

The integration time. This is the time during which the average value is calculated. In the supposition that the instrument takes 10 readings per second, if an integration time of 5 seconds is selected the flow rate reading will be the average of the last 50 readings. If an integration time of 10 seconds is selected the flow rate reading will be the average of the last 100 readings. Logically, when there are fluctuations in the flow rate, the greater the integration time is, the more stable the readings will be.

Filter reset. Whilst the oscillations are within the window defined by the selected % in the filter reset configuration, the filter will average the readings over the established integration time. When there are readings outside this window the averaging of the readings will start again and the flow rate reading can give the instantaneous reading. In these cases the filter reset window must be increased to obtain a more stable reading. The only inconvenience in leaving the window at very high levels is that the response to a sharp change in flow rate will be slower.

3. **The instrument shows empty pipe**

Even when that it has been checked that the pipe is full, if there is empty pipe indication, this may be caused by electrical currents that flow in the liquid in the pipe. This problem is more common when the pipe is made of plastic or other insulating material. To eliminate this problem the metallic housings should be disconnected from the mains earth. Some electronic units have the possibility to disconnect the empty pipe detection

MAINTENANCE

It is recommended to clean the electrodes in installations where appreciable incrustations or sedimentations can occur. Dirty electrodes can cause unstable readings and in extreme cases indication of empty pipe detection

Cleaning can be done using liquid detergents and medium hard brushes.

The Flomat-Tap System allows maintenance of Flomat sensors without having to stop flow of the liquid in the pipe. If you have one of these, refer to its instruction manual for operation.

TECHNICAL CHARACTERISTICS:

Minimum recommended liquid speed : 0.5 m/s

Maximum working temperature : 90 °C

Maximum working pressure : 1.6 MPa (16 bar)

Ingress protection: IP 65

WARRANTY

Tecfluid S.A. GUARANTEES ALL ITS PRODUCTS FOR A PERIOD OF 24 MONTHS, after consignment, against all defects in materials and workmanship.

This warranty does not cover failures which can be imputed to misuse, use in an application different to that specified in the order, the result of service or modification by un-authorized persons, bad handling or accident.

This warranty is limited to cover the repair or replacement defective parts which have not been damaged by misuse.

This warranty is limited to the repair of the equipment and all further and eventually following damages are not covered by this warranty.

Any consignment of equipment to our factory or distributor must be previously authorised. The consignment should be done with the equipment well packed, clean of any liquids, grease or hazardous materials. Tecfluid S.A. will not accept any responsibility for damage done during transport.

Together with the equipment, a note should be enclosed indicating the failure observed, the name, address and telephone number of the sender.

TECFLUID
B.P. 27709
95046 CERGY PONTOISE CEDEX (FRANCE)
Tél. 01 34 64 38 00 – Fax. 01 30 37 96 86
Internet : www.tecfluid.fr