

# Instruction Manual

## 1. RECEPTION

The complete assembly is supplied with the sensor probe (4) dismounted from the extractor. Check to make sure that the sensor probe (4) has not been bent or scratched which could provoke leaks or damage to the O ring (2.1). Mount the sensor probe in the extractor and check that it moves smoothly when the handle (3.2) is turned. Do not feed the sensor probe into the branch without having previously checked that the valve (1.1) is completely open. To make easier the installation of the branch (1) in the pipe, remove the sensor probe and the extractor from it (see parts 4 & 5).

## 2. INSTALLING THE BRANCH

To get a reliable reading the pipe should always be full and most important is that the electrodes should always be covered with liquid. To obtain the best results it is recommended that the sensor should be installed in a rising pipe. In this way the electrodes will always be covered with liquid and air accumulation, which could produce bad readings, is avoided. It is recommended to install the sensor within the 120° arc (fig. 1) and in the event of getting air in the pipe the electrodes will still be covered.

The sensor should be installed in a straight section of pipe free of obstacles (valves etc.), reductions in diameter and bends with a minimum of 10 DN before and 5 DN after the sensor.

A 60,5 mm diameter hole should be made in the pipe for welding the branch (1).

The end of the sensor should penetrate 15% of the pipe DN inside the pipe (see fig. 2). For this purpose the following table will give the distance "X" between the valve (1.1) and the interior of the pipe for the three models and different pipe diameters. To get the distance from the pipe exterior to the valve, just subtract the pipe thickness from "X".

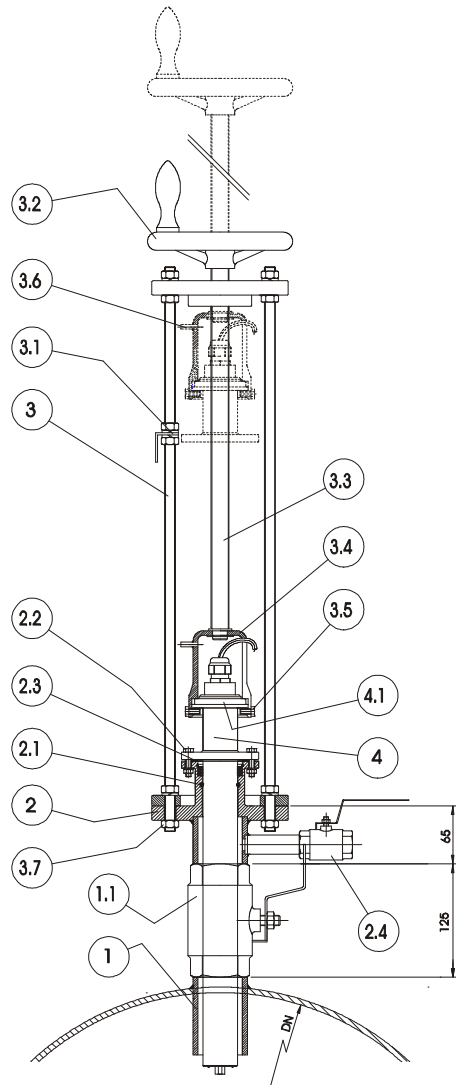

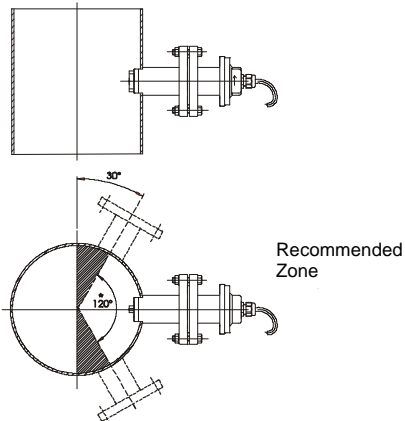

\* Correct mounting to avoid air pockets and dirt deposits in the pipe

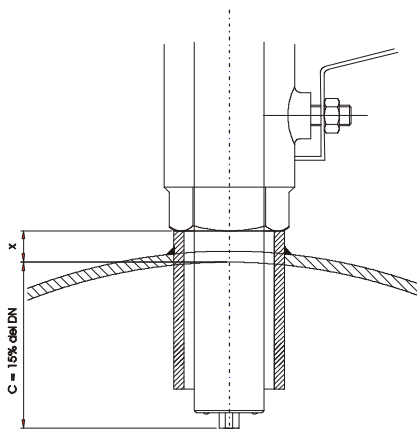

Fig. 2

Fig. 1

FLOMAT TAP DN 100.....600 PN-10				TAP DN 700...1200 PN-10		TAP DN 1400...2000 PN-10	
DN	"X" (mm)	DN	"X" (mm)	DN	"X" (mm)	DN	"X" (mm)
100	115	300	85	700	120	1400	140
125	111	350	77	800	105	1600	110
150	105	400	70	900	90	1800	80
200	100	500	55	1000	75	2000	50
250	92	600	40	1200	45		

The centre line of the sensor should be perpendicular to the pipe centre line.

The position of the sensor flange holes "A" with respect to the pipe centre line should be as fig. 3 to align the electrodes perpendicular to the flow direction.

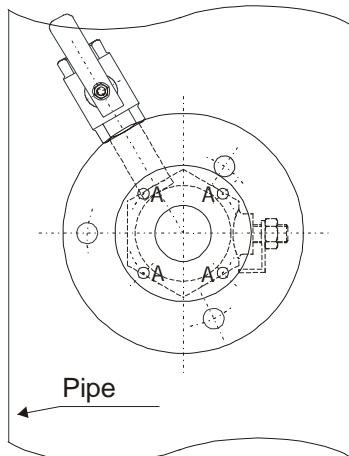

Fig. 3

### 3. SENSOR MOUNTING

- 3.1 Lubricate the O ring (2.1) with Vaseline.
- 3.2 Mount the extractor assembly (3) on the flange (2) and fasten it with the three nuts (3.7).
- 3.3 Open the drain cock (2.4) (with the handle in line with the valve).
- 3.4 Place the flat rubber gasket (2.3) on the sensor flange.
- 3.5 Introduce the sensor (4) in the branch, guiding it until the end just passes the O ring and turn the sensor arrow to the flow direction.
- 3.6 Couple the extractor to the sensor and fasten the sensor head with the two screws (3.5). Feed in the sensor with the handle (3.2) until the index (3.6) coincides with the centre of the label (3.1).
- 3.7 Close the drain cock (2.4) (with the handle perpendicular to the valve) and open the valve (1.1) with its handle perfectly aligned with the sensor centre line.
- 3.8 Feed in the sensor, using the handle (3.2), until seated on the flange and fasten it with the four screws (2.2) checking that the arrows on the sensor head are aligned with the flow direction.

### 4. REMOVING THE EXTRACTOR

- 4.1 Remove the screws (3.5).
- 4.2 Withdraw the extractor head (3.4) about 100 mm using the handle (3.2).
- 4.3 Remove the three nuts (3.7).
- 4.4 Remove the extractor assembly.

### 5. REMOVING THE SENSOR

- 5.1 Check that the extractor head (3.4) is above the level of the sensor head.
- 5.2 Position the extractor in the flange (2) and fasten it with the three nuts (3.7).
- 5.3 Feed in the extractor head (3.4) until it is located over the sensor head (4.1) and makes a small pressure on it.
- 5.4 Mount the two screws (3.5) and tighten, making sure that they are below the sensor head (4.1).
- 5.5 Loosen the screws (2.2) **making sure that the sensor does not rise due to the pressure inside the pipe.**
- 5.6 Remove the screws (2.2).
- 5.7 Withdraw the sensor using the handle (3.2) until the index (3.6) coincides with the centre of the label (3.1).
- 5.8 Close the valve (1.1) and open the drain cock (2.4), checking that the valve (1.1) is not leaking.
- 5.9 Withdraw the sensor completely with the handle (3.2).
- 5.10 Take out the screws (3.5) and remove the sensor from the extractor.

NOTE: In the event of leaving the extractor installed it is recommended to grease the screw regularly to avoid oxidation since it is not stainless steel.

In the event of leaving the branch without a sensor installed it is recommended to mount a blind flange to avoid dirt getting inside.

### Accessories

Blind flange to protect the inside of the branch when left without a sensor.

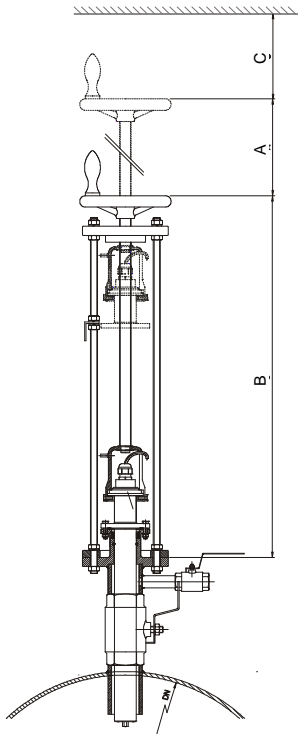

## MINIMUM LENGTH FOR DISMOUNTING

DN max.	Length in mm			
	A	B	C	Total
600	385	720	140	1245
1200	480	830	140	1450
2000	588	960	140	1688

## WARRANTY

Tecfluid S.A. GUARANTEES ALL ITS PRODUCTS FOR A PERIOD OF 12 MONTHS, maximum 18 months after consignment, against all defects in materials and workmanship.

This warranty does not cover failures which can be imputed to misuse, use in an application different to that specified in the order, the result of service or modification by un-authorized persons, bad handling or accident.

This warranty is limited to cover the repair or replacement defective parts which have not been damaged by misuse.

This warranty is limited to the repair of the equipment and all further and eventually following damages are not covered by this warranty.

In the event of consignment of equipment to our factory, this should be done with the equipment well packed and prepaid transport, clean of any liquids, grease or hazardous materials. Tecfluid S.A. will not accept any responsibility for damage done during transport. Together with the equipment, a note should be enclosed indicating the failure observed, the name, address and telephone number of the sender.

---

TECFLUID  
B.P. 27709  
95046 CERGY PONTOISE CEDEX (FRANCE)  
Tél. 01 34 64 38 00 – Fax. 01 30 37 96 86  
Internet : [www.tecfluid.fr](http://www.tecfluid.fr)