



INSTRUCTIONS MANUAL



TABLE OF CONTENTS

1	INTRODUCTION	3
2	INSTALLATION INSTRUCTIONS	3
2.1	Power supply connection.....	4
2.2	Analog output connection.....	4
2.3	Pulse output connection.....	4
2.4	Remote partial reset connection.....	5
2.5	Connection of digital outputs	5
2.6	Sensor connection	6
3	BASIC FUNCTIONS DESCRIPTION.....	6
3.1	Control Panel	6
3.2	Power up.....	7
4	SET-UP.....	8
4.1	Flow rate set-up.....	8
4.1.1	Sensor factor	8
4.1.2	Electronics Factor.....	8
4.1.3	Measuring units.....	9
4.1.4	Decimals.....	9
4.1.5	Nominal flow rate	9
4.1.6	Minimum flow rate (dropout)	9
4.2	Pulse output.....	10
4.2.1	Frequency (Hz)	10
4.2.2	Pulses per measuring unit	10
4.3	Analog output	11
4.3.1	Beginning of scale	11
4.3.2	End of scale	11
4.4	Digital outputs	11
4.4.1	Output 1 mode.....	12
4.4.2	Output 2 mode.....	12
4.5	Filter configuration.....	13
4.5.1	Integration time	13
4.5.2	Filter reset.....	13
4.6	Preferences	14
4.6.1	Default working screen	14
4.6.2	Totalizing mode.....	14
4.6.3	Language	15
4.7	Test	16
4.8	Version.....	17
5	BATCHING.....	17
5.1	Preset entry.....	17
5.2	Batching	17
6	TOTAL VOLUME COUNTER.....	17
7	STATUS INDICATION	18
8	EXAMPLES OF USEFUL CALCULATIONS.....	18
	Measurement error corrections	18
	Change of units of measurement.....	18
9	TECHNICAL CHARACTERISTICS	19
9.1	Power supply	19
9.2	User programmable pulse output	19
9.3	Analog output.....	19
9.4	Digital outputs	19
9.5	Reset input	19
9.6	Front panel.....	19
9.7	Display	19
9.8	General characteristics.....	19
9.9	Directives	19

1 INTRODUCTION

The Flomid-MX electronic control unit adapts to the different Flomid and Flomat series electromagnetic flow sensors.

The microprocessor electronic circuit offers the following functions:

- Pulsed coil excitation to obtain a minimum zero drift.
- User programmable pulse and 4-20 mA outputs proportional to the flow rate.
- Outputs for batching and alarms.
- Local indicator, orientable in four positions.
- Mounting: compact or separate from the sensor.
- Easily removable from the sensor for maintenance.

2 INSTALLATION INSTRUCTIONS

For the electrical connection, the Flomid-MX has two terminal strips situated at the rear of the instrument.

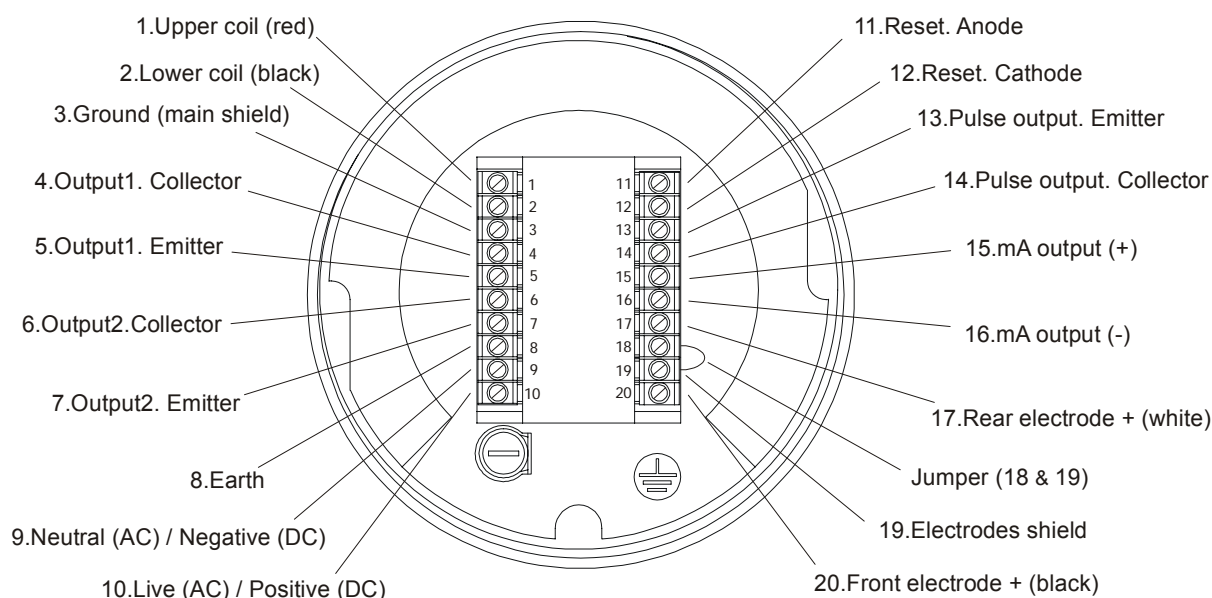

For the electrical installation it is recommended to use multiple conductor cables with individual cable sections in the order of 0.25 to 0.5 mm² in order to make it easier to connect. It is better to maintain the cables with mains voltage (power supply, relays etc.) separated from the cables with low level signals (pulse output, 4-20 mA etc.)

Before starting the installation, check that the cable glands are the right size for the cables to be used, this will guarantee the instrument will stay watertight. The PG 11 cable glands used are for cables with outside diameters between 6 mm and 10 mm.

Peel the outside insulation to free the inner cables to a length that will allow the end of the outside cover to just pass the cable glands when the cables are connected. The fine cables should not be too short to avoid them being under tension or too long to avoid them getting in the way when the rear cover is screwed on. It is recommended to tin the ends of the wires to avoid loose ends which can produce short circuits..

Once the wiring is finished make sure that the cables are well gripped by the cable glands, screw the rear cover in place and fix it with the grub screw.

IMPORTANT: In order to comply with the electrical safety requirements as per EN-61010-1 (IEC 1010-1), the installation of the equipment must take into account the following:

- A mains switch must be provided to disconnect the equipment. This switch must be marked as the disconnecting device for the equipment and be within easy reach of the operator.
- The mains supply must have an earth line.

Before starting to install the equipment, check that the supply voltage available is the same as marked on the label of the instrument.

2.1 Power supply connection

Terminal	AC Power supply	DC Power supply
8	Earth.	Earth
9	Neutral.	0 V (-)
10	Live.	+ 24 V (+)

The earth connection is most important due to the presence of a mains filter which requires this connection.

2.2 Analog output connection

Terminal	
15	mA (positive).
16	mA (negative).

The mA output is an active output, which means that the receiver instrument connected to it should have a passive input. It is recommended that the receiver should have an input resistance of less than 700 ohms to guarantee the full scale output.

2.3 Pulse output connection

Terminal	
13	Emitter.
14	Collector.

The pulse output is a NPN opto-isolated bipolar transistor. The maximum load supported by this transistor is 50 mA and the maximum voltage is 30 V.

In the event of employing inductive loads, such as relays, the use of a free wheeling diode is necessary and should be connected as shown below.

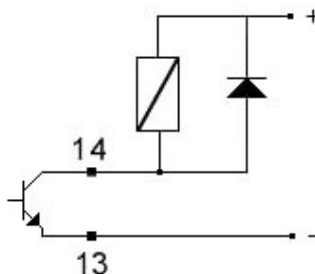

2.4 Remote partial reset connection

Terminal	
11	Anode.
12	Cathode.

This input is for connecting a remote push button to reset the partial volume counter, which is used principally for starting batching processes. These terminals are configured to be activated by a potential free normally open push button.

The reset input can be connected to the input of an opto-isolator as shown below. The minimum current required to activate this input is about 2 mA, which can be obtained by applying a

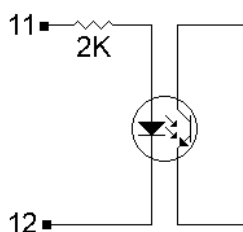

minimum voltage of 5 Vdc to the input. (+ to terminal 11 and – to terminal 12). To do this the instrument must be opened at the front, the printed circuits must be withdrawn and the JP1 and JP2 jumpers must be changed to position 1-2.

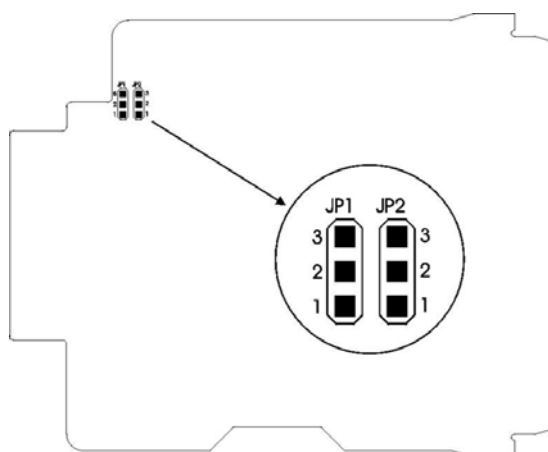

The push button contact must be a good quality snap action switch to guarantee correct working at low voltages and reduce contact bounce to a minimum.

2.5 Connection of digital outputs

The digital outputs are NPN opto-isolated bipolar transistors with the same characteristics as the pulse output (see part 2.3).

Terminal	
4	Collector output 1.
5	Emitter output 1.
6	Collector output 2.
7	Emitter output 2.

In the event of employing inductive loads, such as relays, the use of a free wheeling diode is necessary and should be connected (see part 2.3).

2.6 Sensor connection

When the sensor is separate from the electronics the sensor cable is connected at the rear of the instrument. The connections are the following:

Terminal	
1	Top coil (red)
2	Bottom Coil (black)
3	Ground (main shield)
17	Rear Electrode (white)
18	Jumper to terminal 19
19	Electrodes shield
20	Front electrode (black)

3 BASIC FUNCTIONS DESCRIPTION

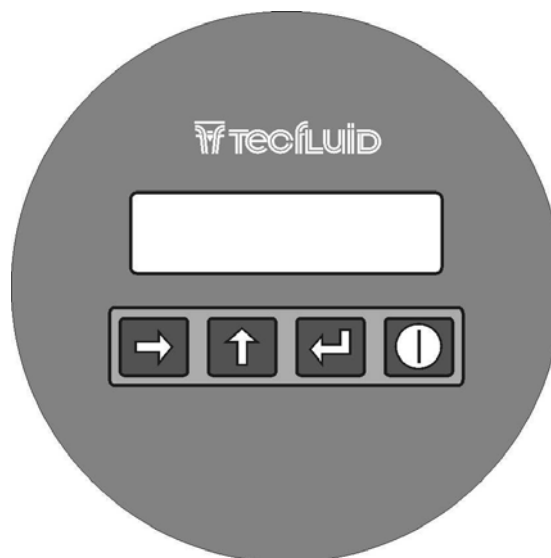

The Flomid-MX has four push buttons for the setting up and operation of the instrument.



NOTE: When two push buttons should be pushed together, it is recommended to push first one, then the second and then release both at the same time.

3.1 Control Panel

-  Push button

 - To enter into the batch quantity set-up mode.
 - Together with the  push button, to enter the set-up
 - Together with the  push button, to reset the total volume counter

Set-up mode

 - To move to the next digit.
-  Push button

 - To start a batching process.

Set-up mode

 - To confirm the data entered.

3. **↑** Push button
 - To change the display between flow rate, total volume or partial volume.
 - Together with **→** to enter in the set-up mode
 - Set-up mode**
 - To rotate between the set-up mode options.
 - To increment the value of a digit.
4. **⏏** Push button
 - To stop a batching process.
 - Together with the **→** push button, to reset the total volume counter.
 - Set-up mode**
 - To exit a set-up mode option without storing modified data (Escape).
5. LCD Display (16 character x 2 lines).
6. Jumper to inhibit push buttons.
Opening the front cover of the instrument, a jumper situated on the left hand side printed circuit can be accessed. Removing this jumper will inhibit all of the push buttons, that is to say that the instrument will not respond to any push button.

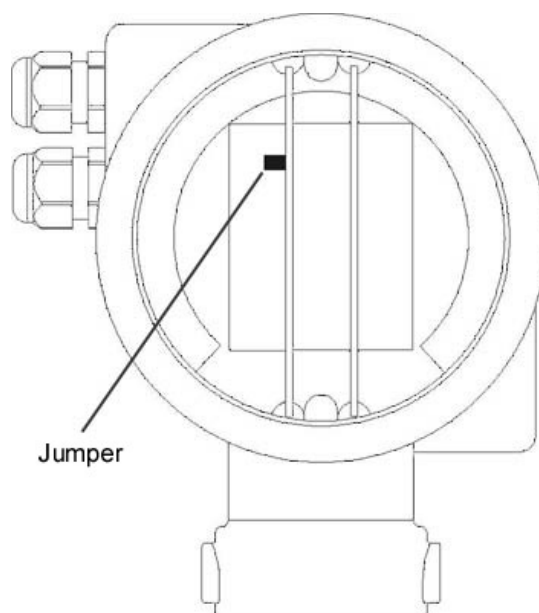



3.2 Power up

When the power supply is switched on the display will show the power up screen and after the default working screen.

T	e	c	f	l	u	i	d			F	L	O	-	M	X
		V	e	r	s	i	o	n		X	.	X			

4 SET-UP

Set-up mode can be accessed by pressing the  and  push buttons at the same time, to avoid unwanted changes due to accidental access.

4.1 Flow rate set-up

F	l	o	w		r	a	t	e		s	e	t	u	p	

In this submenu the parameters which affect the flow rate calculations are introduced:

- Sensor factor
- Electronics factor
- Measuring units
- Number of decimal points
- Nominal flow rate
- Minimum flow rate (dropout)





Pressing the  push button, the screen for entering data of the first parameter appears.

4.1.1 Sensor factor

To start with we must enter the factor to adapt the control unit to the sensor to be used.

In the first screen the calibration factor which appears on the sensor identification label should be introduced.

S	e	n	s	o	r		f	a	c	t	o	r			
		>	1	.	0	0	0	0	0						

When the screen appears the cursor of the digit to be modified is the underline of the digit. The  push button is used to increment the value of the digit. Once the desired value is reached, by pressing the  push button the cursor will pass to the next digit to be modified. On the last digit by pressing the  push button the cursor will pass to the first digit. On pressing the  push button the data displayed on the screen will be stored in memory and the next programming screen will appear.

If you want to exit the programming screen without storing the data in memory, even if changes have been made, then press the  push button.

NOTE: A factor $F_c = 0.00000$ will not be accepted.

4.1.2 Electronics Factor

Once the sensor factor has been stored the next screen for introducing the electronics calibration factor will appear. In this screen the calibration factor on the identification label of the electronics unit must be introduced.

E	l	e	c	t	.		f	a	c	t	o	r			
		>	1	.	0	0	0	0	0						

Once the minimum flow has been configured the set-up returns to the main menu showing flow rate set-up.

Pressing the **↑** push button the next item on the main menu is displayed

4.2 Pulse output

		P	u	l	s	e		o	u	t	p	u	t		

To enter this submenu the **↵** push button is pressed.

Two possibilities exist for this set-up and are selected using the **↑** push button.

		P	u	l	s	e		o	u	t	p	u	t		
		F	r	e	q	u	e	n	c	y		H	z		

		P	u	l	s	e		o	u	t	p	u	t		
			P	u	l	s	e	s	/	u	n	i	t		

Pressing the **↵** push button the option displayed is selected.

4.2.1 Frequency (Hz)

The instrument will give a frequency output proportional to the flow rate for flow speeds between 0 and 10 m/s, and it will be 1000 Hz when the flow rate coincides with Qnom. (see 4.1.4). The frequency will be zero when the flow rate is below the minimum flow rate (see 4.1.6). The minimum frequency output in this mode is 10 Hz.

4.2.2 Pulses per measuring unit

		P	u	l	s	e	s	/	u	n	i	t			
		>	0	0	.	5	0	0							

The pulse output will give the pulses corresponding to the volume flowing through the sensor. This mode is useful for PLC and counter inputs.

NOTE: In the pulse/unit mode the maximum frequency is 2 Hz. If the flow rate is higher than that required to give 2 Hz, then the output frequency will drop to zero.

NOTE: In the event of using electromechanical counters make sure that the counter will accept the maximum frequency that can occur at the output.

Once the pulse output has been configured, we can choose the pulse width between two options: A 50% duty cycle square wave or a pulse width of 65 ms with the output active.

		P	u	l	s	e		w	i	d	t	h			
								5	0	%					

P	u	l	s	e		w	i	d	t	h				
						6	5	m	s					

After the option is chosen, the set-up returns to the main menu. Pressing the  push button the next item on the main menu is displayed

4.3 Analog output

A	n	a	l	o	g		o	u	t	p	u	t		

This is a 4 – 20 mA output proportional to the flow rate. To configure the beginning and end of the scale the  push button must be pressed.

4.3.1 Beginning of scale

This is the flow rate value corresponding to the beginning of the analog scale (4 mA).

B	e	g	.		o	f		s	c	a	l	e		
		>	0	0	0	0	0	0	0			l	/	h

The flow rate is entered in the measuring units programmed as in part 4.1.3.

4.3.2 End of scale

This is the flow rate value corresponding to the end of the analog scale (20 mA).

If a value for the full scale which is equal or less than the beginning of the scale is introduced, then this value will not be accepted and the cursor will go back to the first digit.

E	n	d		o	f		s	c	a	l	e			
		>	0	0	0	7	0	0	0			l	/	h

Once the analog scale has been configured the set-up returns to the main menu. Pressing the  push button the next item on the main menu is displayed

4.4 Digital outputs

D	i	g	i	t	a	l		o	u	t	p	u	t	s

Pushing the  push button we access the sub menu to configure the two digital outputs.

4.6 Preferences

		P	r	e	f	e	r	e	n	c	e	s		

In this submenu we can configure other parameters, such as the default working screen and language.

Pressing the  push button we access the configuration of the default working screen.

4.6.1 Default working screen



D	e	f	a	u	l	t		s	c	r	e	e	n	

This is the screen that appears when power is switched on or we go from standby to the working mode. There are three options.

D	e	f	a	u	l	t		s	c	r	e	e	n		
		F	l	o	w		r	a	t	e		m	3	/	h

D	e	f	a	u	l	t		s	c	r	e	e	n			
						T	o	t	a	l			m	3	/	h

D	e	f	a	u	l	t		s	c	r	e	e	n				
						P	a	r	t	i	a	l		m	3	/	h

Using the  push button we can rotate between the three options. Pushing the  push button The displayed option will be selected as the default working screen.

4.6.2 Totalizing mode

In this screen we can select the way that the total volume counter works. We select the action of the counter depending on the flow direction.

	T	o	t	a	l	i	z	e	r		m	o	d	e	

Pressing  we enter to select one of the five possible options.

N	o	r	m	a	l		f	l	o	w				+
I	n	v	e	r	t	e	d		f	l	o	w	.	+

N	o	r	m	a	l		f	l	o	w				+
I	n	v	e	r	t	e	d		f	l	o	w		-

N	o	r	m	a	l		f	l	o	w				-
I	n	v	e	r	t	e	d		f	l	o	w		+

N	o	r	m	a	l		f	l	o	w					+
I	n	v	e	r	t	e	d		f	l	o	w			0

N	o	r	m	a	l		f	l	o	w					0
I	n	v	e	r	t	e	d		f	l	o	w			+

The sign “+” means that the counter will count up when the flow direction is as indicated, the sign “-” means that the counter will count down and the sign “0” means that the counter will be stopped. .
 The normal flow direction is as marked with the + arrow on the sensor body and the inverted flow direction is as marked with the – arrow.

4.6.3 Language

By means of the  push button, we can select between some standard languages or we can introduce a new language. For example.

L	a	n	g	u	a	g	e								
			E	n	g	l	i	s	h						

L	a	n	g	u	a	g	e								
			E	s	p	a	ñ	o	l						

L	a	n	g	u	a	g	e								
			F	r	a	n	c	a	i	s					

L	a	n	g	u	a	g	e								
			O	t	h	e	r								

Pressing the  push button when the preferred language is displayed the set-up returns to the preferences submenu but now with the messages in the language selected.

If we press the  push button when “Other” language is displayed we enter into the process to create messages in a new language.

Before entering into detail on the creation of a new language it is necessary to have clear some concepts about the working of the messages.







- The user has space to store 12 languages.
- The new languages stored cannot be changed.
- The screens within a new language, once stored cannot be changed.

When we create a new option of a language all the screens used by the program will appear in the following way, for example:

			E	n	g	l	i	s	h						
_	_	_	_	_	_	_	_	_	_	_	_	_	_	_	_

On the top line the message to be entered will appear in English. On the bottom line the character “_” will appear to show that this position is empty and the cursor will appear in the first position. In the above example we would have to enter the name of the language.

To program the languages the use of the push buttons is slightly different from the normal use.



1.  Push button
 - To move to the next character.
 - Together with the  push button to store the message.
2.  Push button
 - To decrement the value of the digit (or character).
 - Together with the  push button to store the message.
3.  Push button
 - To increment the value of the digit.
4.  Push button
 - To change from lower case letters to capital letters and vice-versa.

It is not necessary to program all the screen messages in one sitting. The program will let us add letters in places where the position is empty (shown as “_”). It is recommended to program the language name first of all.

Once the name of a new language has been stored then it will automatically appear in the sequence for selecting the preferred language as a defined language.

To add messages of a defined language (if we have only programmed some of the messages of a new language) then we scroll through the options of preferred language until the wanted language is shown:

L	a	n	g	u	a	g	e							
				D	e	u	t	s	c	h				

and then press push buttons  and .

In this case we have entered in the option for programming new languages but the screens that have been programmed beforehand will not be empty. For example:

				E	n	g	l	i	s	h				
_	_	_	_	D	e	u	t	s	c	h	_	_	_	_

We must remember that we can only change the empty positions (“_” symbol)



4.7 Test

						T	e	s	t					

It allows us to check the outputs of the device.

By pressing the key  we enter in the test mode. The following screen appears.

O	u	t		P	u	l				m	A			

By pressing the key , the state of the digital outputs will change. By pressing the key , the state of the frequency output will change. By pressing the key , the analog output will change, from 4 to 20 mA or vice versa. The state of the outputs is shown on the screen.

	0			1				4					
O	u	t		P	u	l		m	A				

With the key , we will leave the test.

4.8 Version

In the last configuration screen, the version of the software is shown.

5 BATCHING

5.1 Preset entry

From the "standby" screen the  push button should be pressed to enter the batching quantity entry.



P	r	e	s	e	t								
		>	0	0	0	1	0	0	0		m	3	

A value of 0000000 will not be admitted

5.2 Batching

To start the batching process, at least one of the two outputs must be configured for batching (see part 4.4.1 and 4.4.2) whilst in the normal working mode, push the  push button. In this moment the partial volume counter will be reset and corresponding output (as configured in 4.4) will be activated. The screen shows the word "Batching" and the partial counter. The batching process will begin and the instrument will count the volume that passes through the sensor and add it to the partial volume counter. When the partial volume counter reaches the preset value the output will deactivate and the batching process finishes. The screen will show the word "Partial" instead of "Batching".



The total volume counter will act as configured in 4.6.2.

If during the batching cycle the  push button is pressed, the output will be deactivated, the batching process will be stopped, although the batch is not finished. In this case the screen will show the word "Partial" instead of "Batching". Assuming that the flow stops when not batching, we can see at what stage the batch was stopped (partial volume counter). If we need to finish a batch which has been stopped then we must preset the difference between the original quantity and the partial counter when the batch was stopped. If there is a power fail during a batching process, the effect will be the same as having pressed the  push button.

For a remote control, to start the batching process there is a **reset input** at the rear terminal block (see 2.4). This input works exactly the same as the  push button.

6 TOTAL VOLUME COUNTER

The total volume counter indicates the total volume that has passed through the sensor as configured in part 4.6.2. This counter is independent of the partial volume counter used in the batching process.

To reset the total volume counter to zero at first we must be in the standby mode and then press the  and  push buttons at the same time.

If the total volume counter is increasing and reaches a value of 9.999.999 units it will overflow on the next count and go to zero. If it is configured to count down and reaches zero on the next count it will go to 9.999.999.

7 STATUS INDICATION

During the normal working mode, some symbols can be displayed on the screen which indicate the status of the instrument.

If the flow rate has risen above the maximum fluid speed (11 m/s) an asterisk (*) will appear in front of the flow rate value.

If the total volume counter has over flown (>9.999.999 or < 0 units) an asterisk (*) will appear in front total volume value.

8 EXAMPLES OF USEFUL CALCULATIONS

Measurement error corrections

The calibration of flow meters is accomplished using, for the liquid, water at 20 °C thus obtaining a calibration for a liquid of density 1 kg/l and viscosity of 1 mPas. If the flow meter is used with a liquid of other characteristics from the above specified or for reasons of turbulences in the flow, measurement errors can be induced.

To correct these types of errors we can modify the value of the body calibration factor Fc introduced in the configuration of the instrument.

Example 1 - Shortage of volume

If we have a flow meter body which specifies Fc = 0.985, and when we check the volume of a batch, we find that instead of having 100 litres as programmed, we only have 95 litres (5% less) and we must apply the following correction:

F _{cn} = Calibration Factor (new)	= ? (1.03684)	$F_{cn} = \frac{F_c \cdot V}{V_r}$
F _c = Calibration Factor (original)	= 0.985	
V = Expected Volume	= 100	
V _r = Real Volume	= 95	

Example 2 - Excess of volume

If we have a flow meter body which specifies Fc = 0.985, and when we check the volume of a batch, we find that instead of having 100 litres as programmed, we only have 105 litres (5% more) and we must apply the following correction:

F _{cn} = Calibration Factor (new)	= ? (0.89545)	$F_{cn} = \frac{F_c \cdot V}{V_r}$
F _c = Calibration Factor (original)	= 0.985	
V = Expected Volume	= 100	
V _r = Real Volume	= 105	

Change of units of measurement

In some cases we need to change the measurement units for batching, for example, instead of working in litres we need to work in kilograms. In this case we will need to know the density of the liquid (ρ).

To change from litres to kilos we must divide the body calibration factor Fc by the density of the liquid to obtain the new factor for programming the instrument. For example, if the liquid has a density of 0.9 and the body calibration factor Fc = 0.985, and we must batch in kilos; we will have to introduce Fc = 1.09444 in the basic configuration to be able to preset directly in kilos.

F _{cd} = Calibration Factor (new density)	$F_{cd} = \frac{F_c}{\rho}$
F _c = Calibration Factor (original)	
ρ = Density of the liquid in kg/litre	

9 TECHNICAL CHARACTERISTICS

9.1 Power supply

Supply voltage: Standard : 220 VAC 50/60Hz, 24 VDC
On order : 240 VAC, 110 VAC, 24 VAC 50/60 Hz

Power consumption: Less than 10 VA

9.2 User programmable pulse output

Frequency mode: 10 - 1000 Hz

Pulse/unit mode: 0 – 2 Hz (minimum 0.01 pulses / measuring unit)

In pulse / unit mode, the pulse output can be programmed for a 50% duty cycle or for a 65 ms pulse width.

Potential free opto-isolated bipolar transistor.

Maximum current: 50 mA

Maximum voltage: 30 VDC

9.3 Analog output

Galvanically isolated.

Range: 4 - 20 mA

Maximum load resistance: 700 Ohm.

9.4 Digital outputs

Potential free opto-isolated bipolar transistor.

Maximum current: 50 mA

Maximum voltage: 30 VDC

9.5 Reset input

Hardware configurable

Current input : Minimum 2 mA

Maximum 10 mA

9.6 Front panel

4 push buttons. Can be mounted in 4 positions at 90 °.

9.7 Display

LCD 2x16 with backlight (except model with DC power supply).

9.8 General characteristics

Ingress protection: IP67

Maximum working temperature: 50 °C for the LCD.

60 °C for the rest of the equipment.

9.9 Directives

This equipment complies with the following EEC directives:

Low voltage (73/23/CEE)

Electromagnetic compatibility (89/336/CEE)

WARRANTY

Tecfluid S.A. GUARANTEES ALL ITS PRODUCTS FOR A PERIOD OF 24 MONTHS, after consignment, against all defects in materials and workmanship.

This warranty does not cover failures which can be imputed to misuse, use in an application different to that specified in the order, the result of service or modification by un-authorized persons, bad handling or accident.

This warranty is limited to cover the repair or replacement defective parts which have not been damaged by misuse.

This warranty is limited to the repair of the equipment and all further and eventually following damages are not covered by this warranty.

Any consignment of equipment to our factory or distributor must be previously authorised. The consignment should be done with the equipment well packed, clean of any liquids, grease or hazardous materials. Tecfluid S.A. will not accept any responsibility for damage done during transport.

Together with the equipment, a note should be enclosed indicating the failure observed, the name, address and telephone number of the sender.

TECFLUID
B.P. 27709
95046 CERGY PONTOISE CEDEX (FRANCE)
Tél. 01 34 64 38 00 – Fax. 01 30 37 96 86
Internet : www.tecfluid.fr

Dans un souci constant d'amélioration, les caractéristiques données dans nos notices techniques peuvent être changées sans préavis.