



Instruction Manual



Models

- M21/R** Vertical inlet-outlet.
BSP female thread.
- M21/N** Vertical inlet-outlet.
NPT female thread.
- M21/HR** Horizontal inlet-outlet.
BSP female thread.
- M21/HN** Horizontal inlet-outlet.
NPT female thread.
- M21/HRA** Horizontal inlet-outlet.
BSP female thread with valve.
- M21/HNA** Horizontal inlet-outlet
NPT female thread with valve.
- M21/1** Vertical inlet-outlet.
DIN 11851 thread.
- M21/3** Vertical inlet-outlet.
ISO 2852 CLAMP fitting.
- M21/5** Vertical inlet-outlet.
ISO 4200 thread.
- M21/7** Vertical inlet-outlet.
ISO 1145 (SMS) thread.

The following instruction manuals are enclosed:

- AMD Limit Switch Instruction Manual.
- TEH II Transmitter Instruction Manual.
- RCA/RCD Regulator Instruction Manual.

Technical data

- Accuracy: $\pm 4\%$ full scale value. VDE/VDI 3513 class 4.
- Scale length: ≈ 60 mm.
- Scales: Direct in l/h, m³/h, kg/h or in %.
- Mounting: Vertical with rising flow.
- Connections: BSP, NPT threads.
CLAMP and sanitary screw fittings
- Materials: EN 1.4404 (AISI-316L).
- Working pressure:
 - With valve: PN-16. Up to PN-40 on demand
 - Without valve: PN-40. Up to PN-400 on demand
- Fluid working temperature:
 - Without limit switch or transmitter: -80°C to 210°C
 - With limit switch or transmitter: -20°C to $+180^{\circ}\text{C}$ with an ambient temperature of 20°C
- Mounting length:
 - 160 mm
 - 136 mm (horizontal inlet-outlet)
- Indicator box: IP-65 in plastic coated aluminium

- Conforms to the Directive 97/23/EC (Pressure Equipment)



This equipment is considered to be a pressure accessory and **NOT** a safety accessory as defined in the Directive 97/23/CE, Article 1, part 2.1.3.

- Optional Limit Switches:
 - M21-AMD
Slot type inductive sensor limit switch, according to norm DIN 19234 (NAMUR), mounted in the meter indicator housing. Nominal voltage: 8,2 Vdc

Conforms to the Directive 89/336/EEC (EMC)

- Optional Transmitters:
 - TEH2
Position transducer with analog output. For 2 wire connection. Power supply: 12 to 50 Vdc Output signal: 4-20 mA.

Conforms to the Directive 89/336/EEC (EMC)



Dimensions

BSP, NPT female threads

Models:
M21/R
M21/N

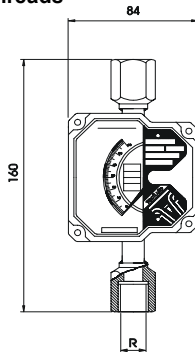

R	A
1/4"	63
1/2"	67
3/4"	72

Horizontal Input-Output

Models:
Without valve
M21/HR
M21/HN
With valve
M21/HRA
M21/HNA

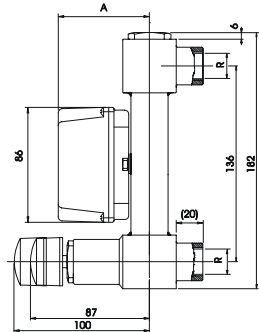

R	A
1/4"	63
1/2"	67
3/4"	72

DIN 11851, ISO 4200, SMS 1145

Models:
M21/1
M21/5
M21/7

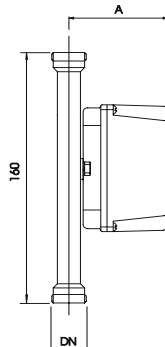

DN	A
10	66
15	68
20	72
25	72

CLAMP ISO 2852

Models:
M21/3

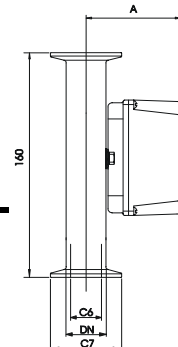

DN	A	C6	C7
12	66	10	34
21,3	68	19,3	34
25	72	22,6	50,5

Working Principle

The flow meter consists of a calibrated orifice and a conical float. The rising flow pushes the float to an equilibrium point. The area between the float and orifice is proportional to the flow rate.

This type of principle is known as variable area.

The equilibrium point depends on:

- The weight of the float: P_f
- The force of the fluid flow: E
- Free area of flow: A_l

The area which is proportional to the flow rate is:

$$A_l = A_o - A_f$$

where

A_o = Area of the orifice

A_f = Float area

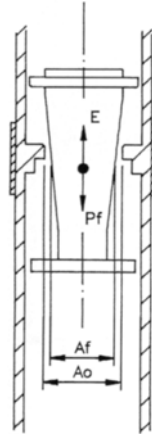

RECEPTION

The M-21 series of flow meters are supplied already calibrated in our calibration rigs, ready for mounting and operation.

The meters are supplied packed for protection during haulage and storage. They also can have float securing elements that should be removed before mounting.

If the inlet/outlet is vertical, with the meter in a vertical position check to see that the float moves freely and that the indicator needle starting from the 0 position follows the float movement along all the scale and returns back to 0.

The float movement should be done manually without jerks and with the flow meter in a VERTICAL position and the 0 end of the scale at the lower end.

INSTALLATION. (Figures 1, 2, 3 and 4)

It should be mounted vertically with a rising flow direction.

It is important that the positioning be fully vertical as deviations of around 5° can give errors through float friction of 8-10% of reading values.

In the case of horizontal flow installation the flow meter should be mounted as shown in Figure 1.

In case of a falling flow installation, the flow meter should be mounted as shown in Figure 2.

We recommend mounting regulation valves, PRIOR to the meter for use with liquids. (Figure 4)

For GASES regulation valves should be mounted AFTER the meter so as to maintain the calibrated working pressure. (Figure 3)



The valves should always be opened progressively as to avoid sudden surges.

FILTERS

It is important to install a filter prior to the meter so as to prevent possible blockages or breakdowns in the measuring system

The filter mesh should be maximum 200 microns.

If there are a lot of magnetic metallic particles in suspension a magnetic filter should be mounted at the meter inlet to avoid particle accumulation within the float's magnetic field which could immobilise it.

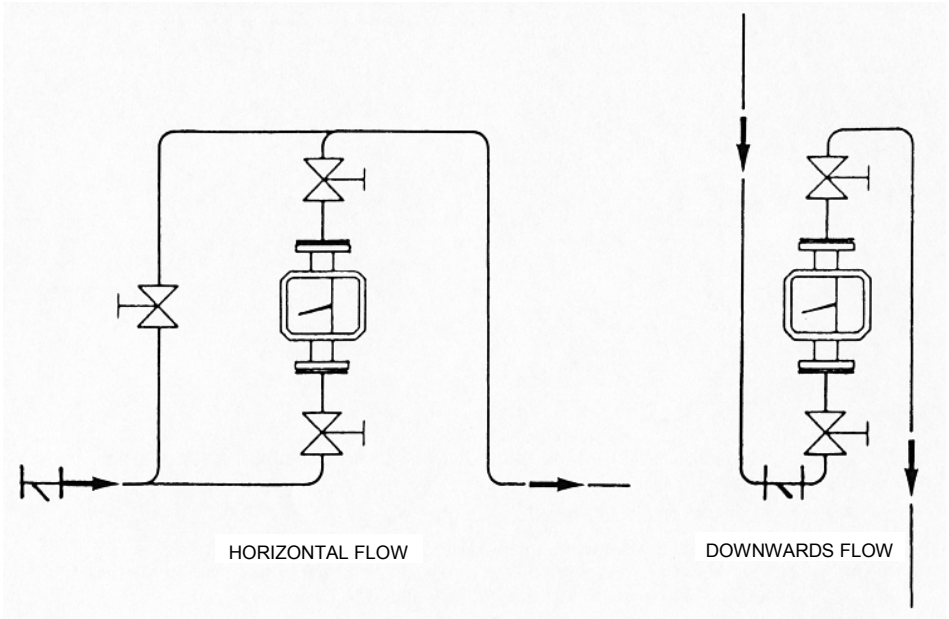

Figure 1

Figure 2

OPERATION

Once the meter is installed, the regulator valve should be opened slowly and the fluid flow will move the float which, through magnetic coupling, moves the indicating needle.



Any variations of working conditions with respect to those when calibrated can induce reading errors. The calibration working conditions are indicated on the instrument's face plate.

LIQUID MEASUREMENT. (Figure 4)

When measuring liquids the regulation valve should be installed as shown in Figure 4.

The by-pass valve should remain closed. The inlet valve (1) is opened slowly to a position which would correspond to a low flow rate, then the meter outlet valve (2) is also opened slowly so as to get rid of the air and then progressively fully opened.

Then, the required flow is regulated by using the inlet valve.



Close the valves during work stoppages or, at the end of the working day to stop sudden surges when started up. If the float hits the stops sharply this could cause damage to the meter.

A FILTER PRIOR TO THE METER IS ALWAYS NECESSARY. If the fluid also contains magnetic particles, which could adhere to the float and jam it, a magnetic filter must be placed at the meter inlet.

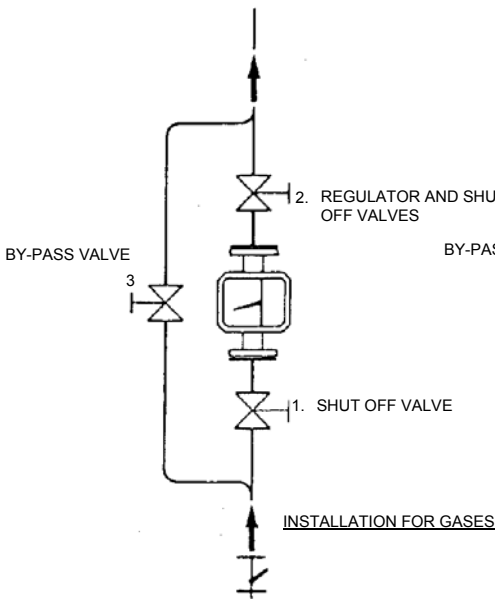

Figure 3

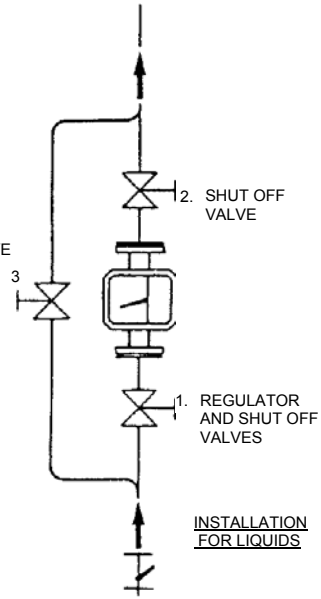

Figure 4

GAS MEASUREMENT. (Figure 3)

THE WORKING PRESSURE IS OF MAXIMUM IMPORTANCE for correct GAS measurement readings as it directly affects the instruments scale.

Therefore if a meter is calibrated for 2 bar and it's working at 1 bar there will be an error of 22%.

In order for the meter to work at the calibration pressure (nominal working pressure) and to obtain a counter pressure that will maintain the floats equilibrium, the regulating valve should be mounted as shown in Figure 3.

The flow should be controlled by the meter outlet valve while keeping the inlet one fully open. The by-pass valve should be fully shut off.

If the regulation is done using the inlet valve, in open circuits or at low gas flow rates, inside the meter the gas will expand which will sharply diminish its density, giving very serious reading errors.

Frequently, if the gas is regulated by the inlet valve, the float experiences an oscillating movement which produces a shut off action until sufficient pressure is gained to overcome its weight. The sudden pressure drop will make it fall when the gas escapes. This cycle is repeated until the valve is closed or fully opened and then closed again, back to the desired flow rate.

This does not mean that this phenomenon will not occur again even if the flow is still regulated by the inlet valve.



The valves must be closed during work stoppages or at the end of the work day to avoid the float from hitting its stop on starting up, which could damage or bend the float when driven with force by the fluid flow.

MAINTENANCE

Indicator housing

If operating anomalies are detected with the meter the following points should be checked. If necessary disassemble the front cover which is held by four M4 screws.

1. THE INDICATOR NEEDLE (3) RUBS ON THE READING SCALE (1).

This normally happens if the meter is hit or dropped. Simply straighten it out by bending it slightly until it is separated by between 2-3 mm from the reading scale surface (1).

2. THE INDICATOR NEEDLE (3) DOESN'T READ 0 ON THE SCALE.

For this, the meter should be placed in its real working position on top of a NON-MAGNETIC table. If when the float is moved the needle moves but does not return to 0, check that the needle hub (4) is firmly attached to the pointer shaft (2). If it isn't, secure the needle hub (4) onto the conical tip (2) of the shaft by tapping it lightly and carefully.

This may have happened during haulage or through the meter being dropped, make the indicator needle coincide with 0 using the adjusting screw on the indicator needle, screw to left or right wherever convenient. Make sure that the shaft (2) is held fast so as not to be bent or damaged.

Check that there is no rubbing between the needle movement system and limit switch or transmitter connecting cables .

This way the flow meter will be properly adjusted to give correct readings.

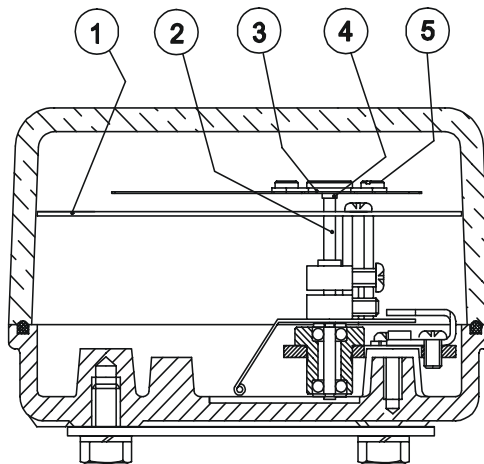

Metering Tube

1. JAMMED FLOAT (M21/R, M21/N, M21/1, M21/3, M21/5, M21/7)

A special tool is necessary to disassemble the flow meter float (1). This tool can be supplied on demand by TECFLUID S.A.

This tool fits over the top float guides.

Once the tool is fitted on the top float guides, the nut (3) is unscrewed using a socket spanner. In this way the nut, the Serrated lockwasher and the bottom float guide can be removed. The float can be extracted from the top.

With the float removed, it can be cleaned and the inside of the flow meter can also be cleaned.

Clean with suitable products and soft brushes, NEVER WITH METALLIC UTENSILS.

To re-assemble the float (1) in the flow meter, proceed as follows:

Introduce the float into the top of the metering tube (the thin end should go first). Do this with care so as not to knock and damage the metering orifice.

Once the float (1) is seated, maintain it in its position using the special tool and turn the instrument upside down. Using a fine rod of 2 to 2.5 mm diameter (for example a fine screwdriver) as a guide, slide the bottom float guide and the washer onto the end of the float. Then mount and tighten the nut (3) using a socket spanner.

Take care to keep the special tool in its correct position during assembly, manually or held in a vice to make assembly easier.

If you are interested in acquiring the special tool from TECFLUID S.A. please indicate for which nominal diameter it is required.

2. JAMMED FLOAT (M21/HR, M21/HN, M21/HRA)

To dismount the float, the plug (5) should be unscrewed and the rubber seal (6) removed.

By turning the instrument upside down the float will slide out. Be careful that the float does not fall and damage itself.

With the float removed, it can be cleaned and the inside of the flow meter can also be cleaned.

Clean with suitable products and soft brushes, NEVER WITH METALLIC UTENSILS.

Once the float is cleaned, slide it carefully back into the metering tube avoiding damage to the calibrated orifice. Make sure that the point of the float is at the bottom of the metering tube.

Mount the seal (6) in its seating and screw in the plug (5) until a good seal is obtained.

3. LACK OF MAGNETIC FIELD

Disassemble the float (1) as previously indicated and check to see if the float has suffered chemical aggression and the permanent MAGNET has been affected. If this is the case, the float must be changed and the flow meter will have to be re-calibrated.

4. READING ERRORS

These can occur if the calibrated orifice and/or the float are not in a good condition. Check its mechanical state for scratching, impact or chemical attack. If the float is in bad condition it must be changed. If the calibrated orifice is damaged the metering tube and the float must be changed. In both cases the flow meter has to be re-calibrated.

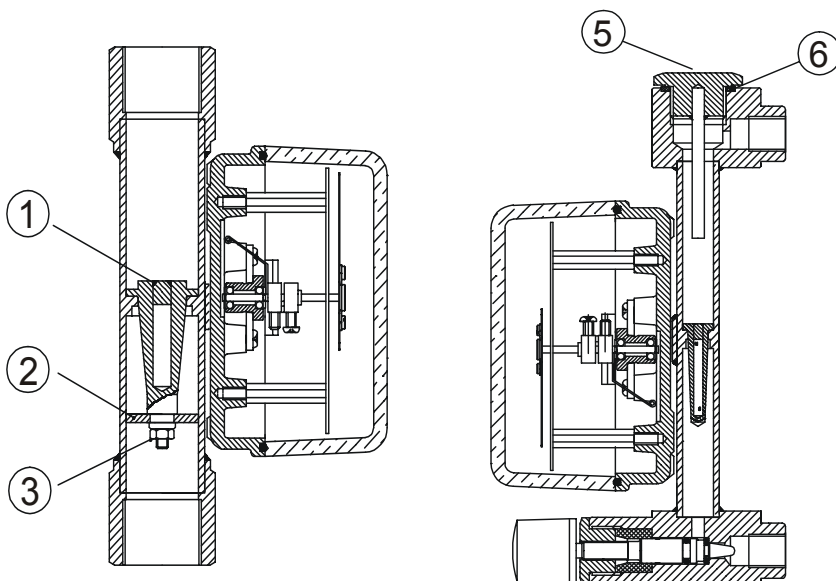

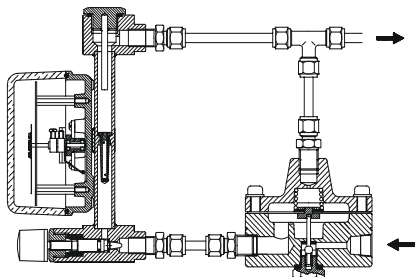

RCA

Models: M21/HRA, M21/HNA

Flow regulator with variable pressure at the regulator inlet and constant pressure at the regulator outlet.

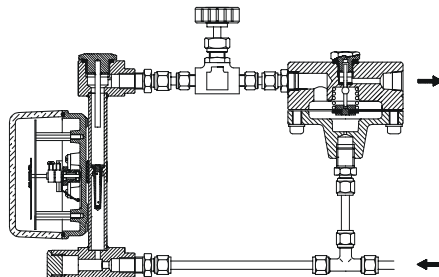

RCD

Models: M21/HRA, M21/HNA

Flow regulator with constant pressure at the regulator inlet and variable pressure at the regulator outlet.

The minimal allowable pressure between inlet and outlet of the regulators must always be over 200 mbar.

WARRANTY

Tecfluid S.A. GUARANTEES ALL ITS PRODUCTS FOR A PERIOD OF 24 MONTHS, after consignment, against all defects in materials and workmanship.

This warranty does not cover failures which can be imputed to misuse, use in an application different to that specified in the order, the result of service or modification by un-authorized persons, bad handling or accident.

This warranty is limited to cover the repair or replacement defective parts which have not been damaged by misuse.

This warranty is limited to the repair of the equipment and all further and eventually following damages are not covered by this warranty.

Any consignment of equipment to our factory or distributor must be previously authorised. The consignment should be done with the equipment well packed, clean of any liquids, grease or hazardous materials. Tecfluid S.A. will not accept any responsibility for damage done during transport.

Together with the equipment, a note should be enclosed indicating the failure observed, the name, address and telephone number of the sender.

TECFLUID
B.P. 27709
95046 CERGY PONTOISE CEDEX (FRANCE)
Tél. 01 34 64 38 00 – Fax. 01 30 37 96 86
Internet : www.tecfluid.fr