

Instructions Manual



Technical Data

- Accuracy: Based on VDE / VDI 3513
 - PT/PS $\pm 4\%$ of full scale value
 - PTM/PSM $\pm 6\%$ of full scale value
- Material:
 - PT/PTM Trogamid T
 - PS/PSM: Polysulphone
- Mounting: Vertical (Rising flow direction)
- Pipe fittings:
 - PT-11/PS-31 BSP female thread
 - PT-12/PS-32 DIN flanges
 - PTM/PSM-01 BSP female thread
 - PTM/PSM-02 DIN flanges
- Max. Working pressure:
 - from 8 to 15 bar at 20 °C depending on the tube
- Max. Fluid temperature: 0 ... +60°C (Trogamid T)
0 ... +90°C (Polysulphone)

- Conforms with the Pressure Equipment Directive 97/23/CE.

CE 0830



This equipment is considered as being a pressure accessory and **NOT** a safety accessory as defined in the 97/23/CE directive, Article 1, paragraph 2.1.3.

Working principle

The flowmeter consists of a float inside a conical tube. The rising flow pushes the float to an equilibrium point. The area obtained between the float and the orifice is proportional to the flow rate.

This type of measuring principle is known as variable area.

The equilibrium point depends on :

- The float weight : P_f
- The fluid thrust : E
- The free flow area : A_l

The area proportional to the flow rate will be:

$$A_l = A_c - A_f$$

where:

A_c = Flow measuring tube area

A_f = Float area

Each position of the float corresponds to a flow rate indicated on the scale printed on measuring tube.

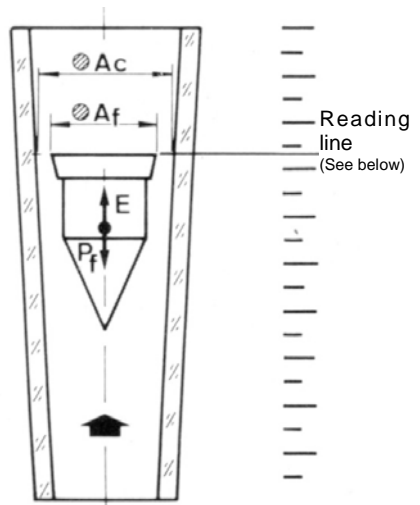

RECEPTION

The flowmeter is supplied ready for installation and service.

The instrument is supplied packed for their protection during transport and storage. Likewise they have blocking elements that should be removed before installation.

Turning the instrument up side down, check that the float moves freely up and down through the whole length of the tube.

INSTALLATION

Before carrying out the installation, verify that the seals are made of a material that is suitable for the fluid to be measured.

The instrument must be installed taking into account the following:

The fluid inlet will be in the bottom of the flowmeter (the one nearest the scale's minimum value).

The fluid outlet will be in the top of the flowmeter (the one nearest the scale's maximum value).

It is very important that the position of the instrument is completely vertical, given that deviations of about 5° can produce errors of about 10% of the reading.

FLOW RATE READING

The float determines the flow rate measurement on the scale.

For the different shapes of floats, the readings must be taken at the height shown in the following drawing.

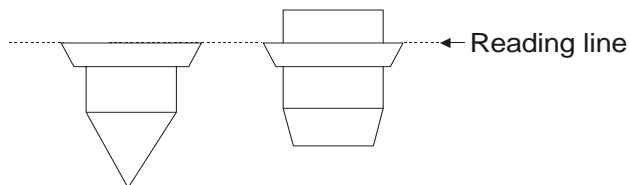

CLEANING AND MAINTENANCE

For routine cleaning, normally it is sufficient to pass a solution of water and detergent through the flowmeter.

If the float is obstructed or the tube is too dirty, the flowmeter must be removed from the line and disassembled in order to clean the tube and the float.

Before remove it, close the supply of fluid to the flowmeter.

Remove the flowmeter from the line, by disconnecting the unit at the top and the bottom (1).

Remove the nuts (2) and the float stops (3).

Remove the float (4).

Now the tube and the float may be cleaned, using an appropriate detergent.

Be careful not to damage the tube when cleaning it. It is recommended to use a cloth.

Important: Never use ethyl alcohol or alcohol-based detergents for cleaning the tube.



There are a large variety of chemical agents that can damage the flowmeter. For this reason it is advisable to contact the manufacturer in case of doubt.

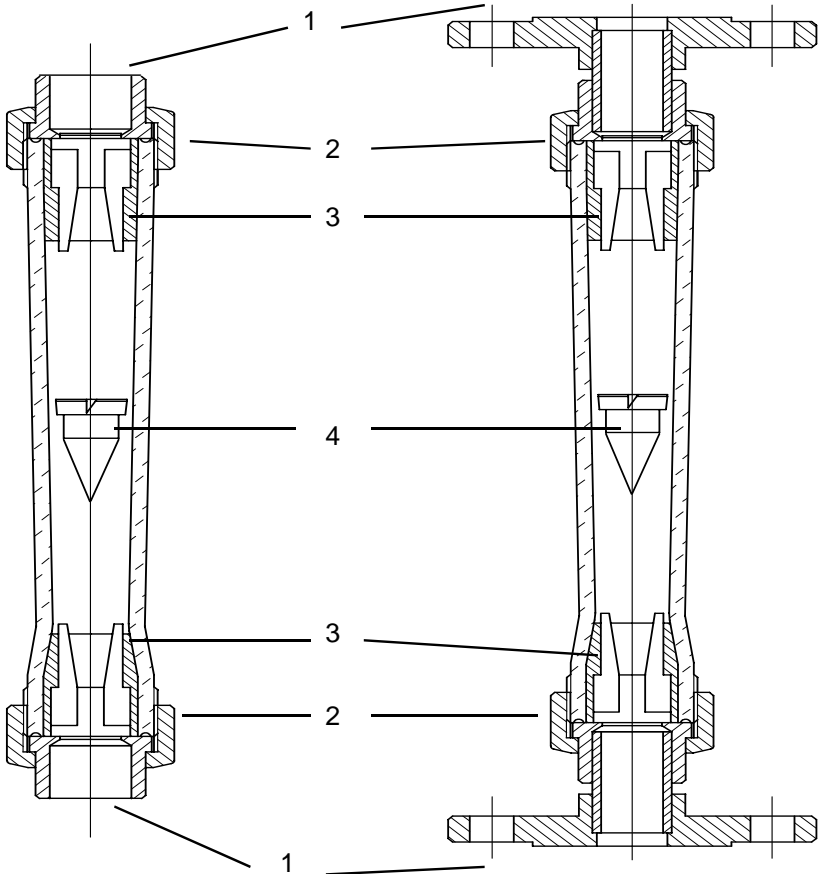

The float must be cleaned with a soft brush, NEVER WITH METALLIC UTENSILS.

To assemble the unit follow the disassembly process in reverse. Insert the float so that the largest diameter is always facing upwards. Before re-installing the flowmeter in the line, verify that the float moves freely through the plastic tube.

REPLACING THE PLASTIC TUBE

To replace the plastic tube follow the process described for the disassembly, assembly and re-installation of the flowmeter, changing the disassembled tube.

WARRANTY

Tecfluid S.A. GUARANTEES ALL ITS PRODUCTS FOR A PERIOD OF 24 MONTHS, after consignment, against all defects in materials and workmanship.

This warranty does not cover failures which can be imputed to misuse, use in an application different to that specified in the order, the result of service or modification by un-authorized persons, bad handling or accident.

This warranty is limited to cover the repair or replacement defective parts which have not been damaged by misuse.

This warranty is limited to the repair of the equipment and all further and eventually following damages are not covered by this warranty.

Any consignment of equipment to our factory or distributor must be previously authorised. The consignment should be done with the equipment well packed, clean of any liquids, grease or hazardous materials. Tecfluid S.A. will not accept any responsibility for damage done during transport.

Together with the equipment, a note should be enclosed indicating the failure observed, the name, address and telephone number of the sender.

TECFLUID
B.P. 27709
95046 CERGY PONTOISE CEDEX (FRANCE)
Tél. 01 34 64 38 00 – Fax. 01 30 37 96 86
Internet : www.tecfluid.fr