



Plastic Flow Meters for gases & liquids, using TROGAMID* & POLYSULFON Technology.

Applications

Monitoring & Control of processes for:

- Water & Waste Water Treatment.
- Chemical, Petrochemical & Paper.
- Pharmaceutical, Cosmetics & Synthetics.
- Refrigeration & Air Conditioning.
- Smelting & Refining.
- Osmosis.
- Gas processes.

Benefits

- Low cost.
- Excellent readability.
- Scaled directly in l/h, m³/h, % etc.
- Temperatures up to 70°C.
- Pressures up to 40 Bar.
- Simple installation (flanged, threaded or glued connections).
- Light weight.
- High & Low Flow alarms.
- 4-20 mA Output (10 point).

* TROGAMID is a registered trade mark of Dynamit Nobel.

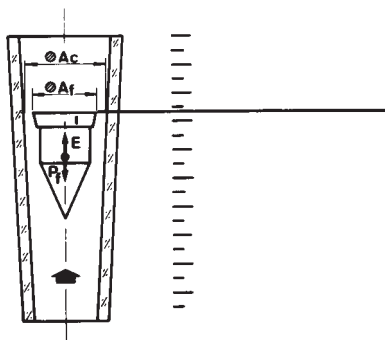

Measurement Principle

Variable area flow using a float in a tapered tube made from special plastic materials.

Operation

The fluid flows up through the tapered tube forcing the float to a position with sufficient free area to enable the flow to pass. This free area is related to the flow rate, the weight of the float and the density and viscosity of the fluid.

The pressure drop across the flow meter remains constant over the entire flow range. This occurs because the pressure drop is related to the fluid velocity and area of flow, the area of flow increases as the flow rate increases.

Technical Data

- Connections:
 - PTM-01 & PSM-01: Threaded or glued of 1/2" and 3/4" PVC fittings.
 - PTM-02 & PSM-02: Flanges DN-15 and DN-20, PN-10. Other connections available on request.
- Length
 - PTM-01/PSM-01 232 ± 1 mm
 - PTM-02/PSM-02 260 ± 1 mm
- Accuracy
 - According to Standards VDE/VDI Class 6.
- Scales calibrated directly in l/h, m³/h, %.
- Scale length 100 ± 5mm.
- Rangeability 10:1.
- Temperature Limits:
 - Trogamid T (tubes) 70°C
 - Polysulfon (tubes) 80°C
 - PVC (connections) 55°C
 - PP (connections) 100°C
- Materials:

Flow Tube	Connectors	Float	Stops
PTM: Trogamid T	PVC/PP	SS/PVC	PVDF
- Alarm Options:
 - PTM-AMM 1...2 Magnetic Actuated micro switch
 - PTM-AMD 1...2 Inductive proximity sensor.
 - PTM-AMO 1...2 Optical position detector.
 - PTM-AMR 1...2 Magnetic actuated reed switch.
- Transmitter Options:
 - PTM-MUR 0...4-20mA. (10 Point resolution).

PTM-01/PSM-01

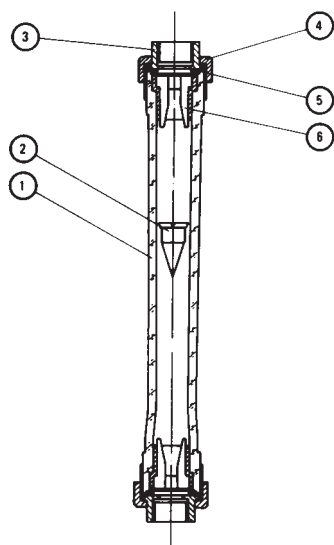

PTM-02/PSM-02

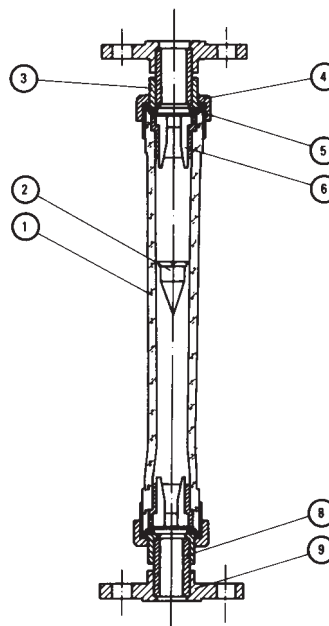

No	Item	PTM-01/PTM-02	PSM-01/PSM-02	Specials
1	Flow Tube	Trogamid T	Polysulfon	-
2	Float	AISI-316, PVDF, Al.	AISI-316, PVDF, Al.	PVDF + Lead, Hastelloy, Titanium
3	Connector	PVC	PP	AISI-316, PVDF, Steel, PTFE, Threaded
4	Nut	PVC	PP	AISI-316, Titanium, Hastelloy
5	O-Ring	Nitrile, Viton®	Nitrile, Viton®	PTFE
6	Stops	PVDF	PVDF	-
8	Tube Union	-/PVC	-/PP	AISI-316
9	Flanges	-/PVC	-/PP	AISI-316

Flow Tube Series PTM ⁽¹⁾	Measuring Range vs Float Type						Max. Pressure	Pressure Drop mm Water		Tube Length mm (±1mm)	Series	
	AISI-316 & PVC-Lead 7.95 g/cm ³			Aluminium 2,85 g/cm ³				Float			DN	E
	Water 20°C l/h		Air @ STP Nm ³ /h	Air @ STP Nm ³ /h		SS-316 PVDF-Pb		Al				
Model No	min	max	min	max	min	max	Bars					
* PTM-312-0040	4	40	-	-	-	-	15	30	-	192	15	20
* PTM-312-0060	6	60	-	-	-	-	15	30	-	192	15	20
PTM-312-0100	10	100	0,3	3	0,15	1,8	15	90	35	192	15	20
PTM-312-0160	16	160	0,5	5	0,25	2,5	15	90	35	192	15	20
PTM-312-0250	25	250	0,7	7	0,4	4	15	90	35	192	15	20
PTM-313-0400	40	400	1,1	11	0,7	7	15	125	50	192	20	25
PTM-313-0630	60	630	1,8	8	1	10	15	125	50	192	20	25
PTM-313-1000	100	1000	3	30	1,7	17	15	125	50	192	20	25

* Range with float in PVDF or PTFE

⁽¹⁾ The same for PSM

PTM-01/PSM-01

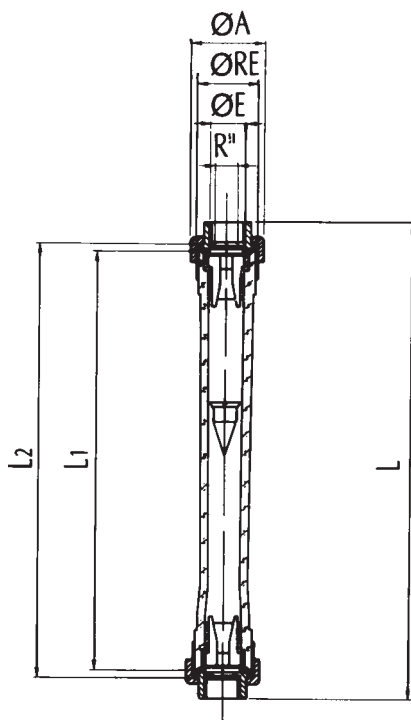

PTM-01/PSM-01

R'' = DN	E	RE	A	L	L1	L2	H
-	15	20	1"	43	232	192	198
3/4"	20	25	1 1/4"	53	232	192	198

PTM-02/PSM-02

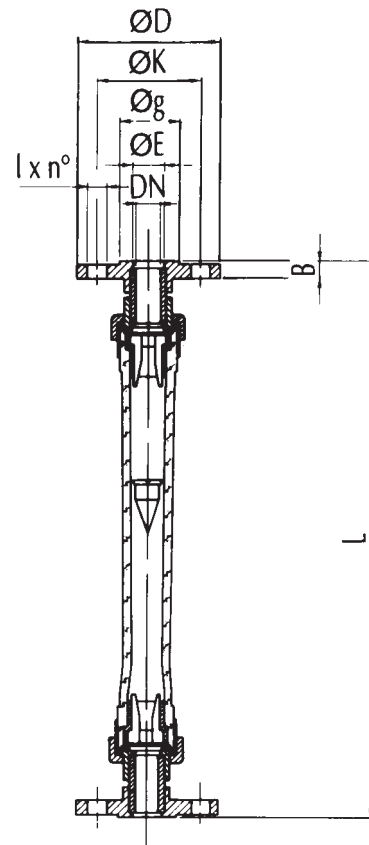

PTM-02/PSM-02

DN	E	D	k	g	1 x n°	B	L
15	20	95	65	45	14x4	12	257
20	25	105	75	58	14x4	13	260



Adjustable Alarms PTM-AMR

Reed switch, actuated by a magnet inside the float.

- Mounted within a plastic enclosure:
PTM-AMR 1...2 Adjustable reed switches.
Connection standard DIN 43650.
IP 65 Protection.
Max. Voltage: 220 Vac, 30 Vdc.
Max. Current: 0.5 A.
Max. Power: 10 VA
Contact Speed: 1.1 ms
Temperature Range: -40 to +150°C
(Use a relay to protect the reed switch, for inductive loads).
- Operation:
The contact is normally open, when not in alarm condition.

DN	15	20
BSP	1/2"	3/4"
A	47	52

- Maximum Flow:
On increasing flow, the contact closes when the float reaches the height of the alarm sensor. It remains closed while the float is above the sensor. It opens again when the flow reduces and the float returns below the sensor.
- Minimum Flow:
On reducing flow, the contact closes when the float reaches the height of the alarm sensor. It remains closed while the float is below the sensor. It opens again when the flow increases and the float rises above the sensor.

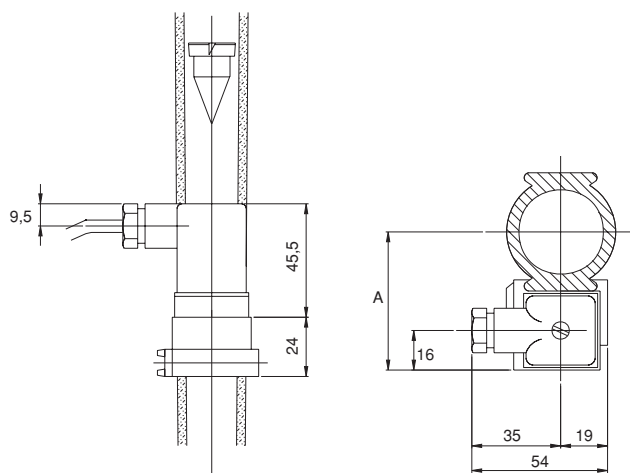

Transmitter PTM/TMUR 0/4-20 mA.

0...4-20 mA Output from a series of reed switches mounted on the side of the flow tube, in a plastic enclosure.

- Separate DIN rail mounted signal converter.
Power Supply: 220/110/24 Vac, 24 Vdc.
Output: 0...4-20 mA.
Connection: 4 wire.
Accuracy: ± 9% of full scale.
Sensor Connection: PE-11 Unpluggable connector to the converter enclosure.

DN	15	20
A	95	105

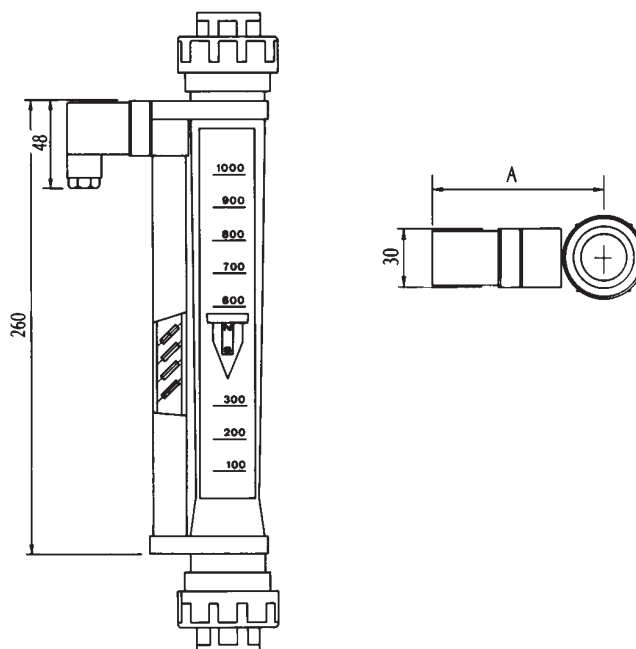

We are at your service, please consult us.
TECFLUID develops and manufactures instruments for gases and liquids, using the most advanced techniques.
Request Information by telephone n° 01 34 64 38 00



B.P. 27709 95046 CERGY PONTOISE CEDEX (FRANCE)
Tél. 01 34 64 38 00 – Fax. 01 30 37 96 86
Internet: www.tecfluid.fr