

Metal Tube Variable Area Flowmeters for Gases, Liquids and Steam

- Metallic construction.
- Indication by magnetic coupling.
- Linear scales, calibrated in l/h, m³/h, kg/h, Tm/h, %, etc
- Sizes DN-15 to DN-150.
- Flow rate:
 - Water: 2.5 l/h up to 180 m³/h.
 - Air: 0.07 Nm³/h up to 5,400 Nm³/h.
- Low Pressure drop.
- Standard Construction: in SS-316, PVC, & PTFE
- Options:
 - Local indication only.
 - 1 or 2 Alarm Settings.
 - 4-20mA Transmitter with 2 or 4 wire system.
 - Pneumatic transmitter 3-15 psi (0.2-1 Bar).
 - Intrinsically safe to Cenelec standard EExibII T5/T6.
 - Flow totaliser.
- Connections:
 - Flanges DN-15 to DN-150 PN-40/PN-16 standard in steel or stainless steel-316
 - On request, flanges to ASA, BTS, etc.
 - Screwed connections.
 - Sanitary screwed connections to DIN 11851.
- Total length including flanges:
 - DN-15...DN-125: 250mm
 - DN-150: 300mm

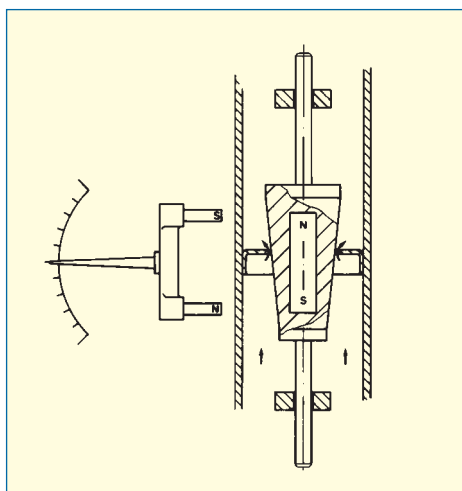



Flowmeter SC-250

The SC-250 is a variable area flowmeter with optional signal transmission. It is designed to provide a high precision measurement according to the accuracy standard class VDE/VDI 3513 of 2.5% and 1.6%.

The float is constructed in a conical form.

Operation

The metering system is made up of a calibrated orifice and a conical float. The force from the fluid, as it flows from the bottom to the top, displaces the float until it reaches an equilibrium point that is a function of:

- The weight of the float. P_f
- The force of the fluid flow. E
- The free area of flow: $A_l = A_o - A_f$

Each float position represents a different equilibrium which has a corresponding flow rate. The position of the float is transmitted to the indicator through a magnetic field from a permanent magnet built into the float.

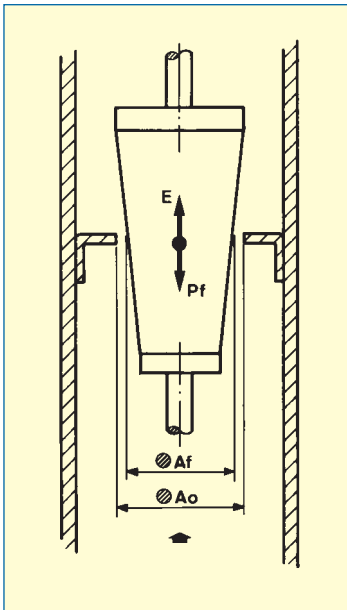

Applications

The SC-250 flowmeters are built in SS-316 with a very robust construction. They are designed to provide a high performance measurement in extreme working conditions. They provide a high resistance to temperature, pressure and corrosion with the use of materials such as AISI-316, Hastalloy, Titanium, PVC, PTFE & PVDF.

These instruments are suitable in all kinds of industries, especially:

- Water treatment.
- Pharmaceutical industry.
- Power plants.
- Nuclear generating plant.
- Chemical and petrochemical industry.
- Pulp & Paper industry.
- Food industry.
- Heating and cooling circuits.
- Saturated steam circuits.
- Oven treatments.

Technical Data

- Accuracy according to VDE/VDI 3513.
 - Standard: $\pm 2.5\%$ of FSD ($\pm 1.5\%$ of Medium value).
 - On request: $\pm 1.6\%$ of FSD ($\pm 1\%$ of Medium value).
- Scales:
 - Direct in engineering units or in %
 - Length: 120mm.
- Scale range: 10:1.
- Temperature of fluid:
 - Standard:
 - 50°C to $+200^\circ\text{C}$ SS-316
 - 20°C to $+125^\circ\text{C}$ PTFE
 - 0°C to $+50^\circ\text{C}$ PVC
 - With thermal separator:
 - 180°C to $+400^\circ\text{C}$ SS-316
- Ambient temperature:
 - 20°C to $+80^\circ\text{C}$ (except PVC type)
- Working pressure:

-SC-250	SS-316
PN-40	DN-15...DN-50
PN-16	DN-65...DN-125
PN-10	DN-150
-SC-250	PVC/PPH/PTFE/PVDF
PN-16	DN-15...DN-125
PN-10	DN-150

Also on request, DIN/ASA/BTS/11851 sanitary.

- Mounting Length:

-SC-250	SS/PTFE/PVDF/PVC/PPH
DN-15...DN-150:	250mm
DN-150:	300mm
- Indicator Box:
 - IP-65 protection in coated aluminium (polyamide 11).

Models

- SC-250/PVC Wetted parts PVC, steel flanges
- SC-250/PPH Wetted parts PPH, steel flanges
- SC-250/PTFE Wetted parts PTFE, steel flanges
- SC-250/.../AMM With adjustable micro switch alarm
- SC-250/.../AMD With inductive alarm (and relay WE 77)
- SC-250/.../TEH With 4-20 mA transmitter (4 wire)
- SC-250/.../TOTH With volume totalizer
- SC-250/.../TTEH Volume totaliser + Analog output
- SC-250/.../TKEX 4-20 mA intrinsically safe transmitter
- SC-250/.../TP1200 With pneumatic tx.(3-15 psi/0.2-1Bar)

The FCV conical floats, as standard, are made from AISI-316, PVC, PPH & PTFE. Other resistant materials are available on request.

The maximum working viscosity for float series FCV is 10mPas. Float series SCM is used for viscosities up to 10000mPas.

Metal Tube Flowmeter SC-250

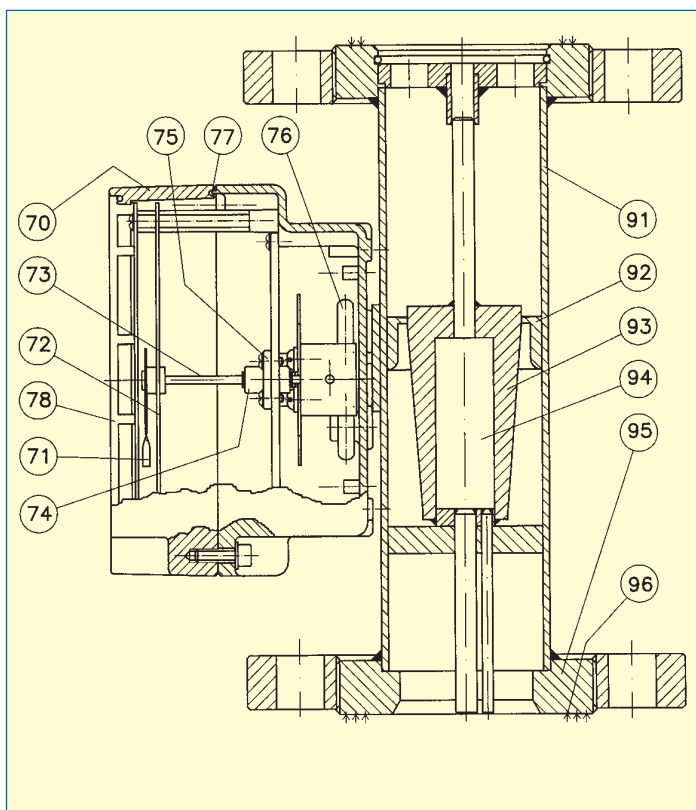

Float DN-15 to DN-80 Float DN-100 to DN-150

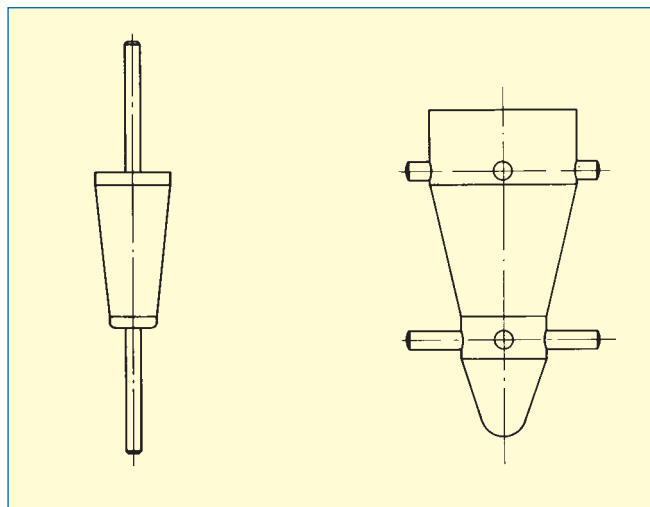

Indication

Item	Description	Materials
70	Enclosure	Coated Aluminium
71	Indicator	Aluminium/Plastic
72	Scale	Aluminium
73	Axis	SS-316
74	Ball Bearing	SS-316
75	Counter Weight	Brass Chrome
76	Magnetic Brake	Supernialco G
77	Gasket	Nitrile
78	Window	Metacrylate

Flow Tube

Item	Description	Materials		
		AISI-316	PVC	PTFE
91	Flow Tube	AISI-316	PVC/SS	PTFE/SS
92	Calibrated Orifice	AISI-316	PVC	PTFE
93	Float	AISI-316	PVC	PTFE
94	Magnet	-----	Supernialco G	-----
95	Flanges	Steel/SS	AISI-316	AISI-316
96	Flange Seat	AISI-316	PVC	PTFE



Standard Scales

DN	Float N°	Float AISI-316			Float PVC				
		l/h Water	Nm³/h Air	OP mm Wtr	l/h Water	OP mm Wtr	Nm³/h Air	OP mm Wtr	
15	15025	2.5-25	0.07-0.7	400	2.5-25	176	0.1-1	309	
	15040	4-40	0.12-1.2	400	6-60	150	0.2-2	240	
	15060	6-60	0.18-1.8	400	10-100	150	0.4-4	240	
	15100	10-100	0.3-3	400	16-160	150	0.6-6	240	
	15160	16-160	0.5-5	500	25-250	150	1-10	240	
	15250	25-250	0.7-7.5	500	40-400	150	1.6-16	240	
	15400	40-400	1.2-12	500	60-600	150	2-20	240	
	15600	60-600	1.8-18	500					
25	25100	100-1000	3-30	600	16-160	80	0.6-6	180	
	25160	160-1600	5-50	700	25-250	80	1-10	180	
	25250	250-2500	7-75	900	40-400	80	1.6-16	180	
	25400	400-4000	12-120	1100	60-600	80	2.5-25	180	
	25101				100-1000	80	4-40	180	
	25161				160-1600	80	6-60	180	
	25251				240-2400	80	9-96	180	
40	40400	400-4000	12-120	450	150-1500	180	5-50	260	
	40600	500-6300	15-180	550	250-2500	180	8-80	260	
	40800	800-8000	24-240	900	400-4000	180	14-140	260	
50	50800	800-8000	24-240	700	250-2500	150	9-90	220	
	50100	1000-10000	30-300	900	400-4000	150	15-150	220	
	50150	1500-15000	45-450	1000	600-6000	150	20-200	220	
	50101				1000-10000	150	35-350	220	
65	65150	1500-15000	45-450	700	800-8000	150	25-250	220	
	65200	2000-20000	60-600	1000	1000-10000	150	40-400	220	
80	80020	2000-20000	60-600	800	1000-10000	160	40-400	230	
	80025	2500-25000	75-750	1000	1600-16000	160	60-600	230	
	80030	3000-30000	90-900	1200					
100	81040	4000-40000	120-1200	1000	1600-16000	170	60-600	240	
	81050	5000-50000	150-1500	1200	2000-20000	170	100-1000	240	
	81060	6000-60000	180-1800	1500					
125	82080	8000-80000	240-2400	1200	3000-30000	180	150-1500	280	
	82100	10000-100000	300-3000	1500	4000-40000	180	200-2000	28	
	82120	12000-120000	360-3600	1800	6000-60000		220-2200		
150	83150	15000-150000	450-4500	2200	8000-80000	230	250-2600	320	
	83180	18000-180000	500-5400	2200	10000-100000	230	300-3200	320	

Sizes and Weights DIN Standard (Sizes in mm)

DN	D	k	g	lxn°	B	PN	A Flanges Kp/cm ²	C	L	Weight Kg
15	95	65	45	14x4	14	40	114	45	250	3.5
25	115	85	68	14x4	16	40	120	45	250	4.5
40	150	110	88	18x4	16	40	126	45	250	7.3
50	165	125	102	18x4	18	40	130	45	250	8.3
65	185	145	122	18x4	18	16	130	45	250	10
80	200	160	138	18x8	20	16	142	45	250	12
100	220	180	158	18x8	20	16	150	-	250	15
125	250	210	188	18x8	22	16	162	-	250	20
150	285	240	212	23x8	22	16	180	-	300	32

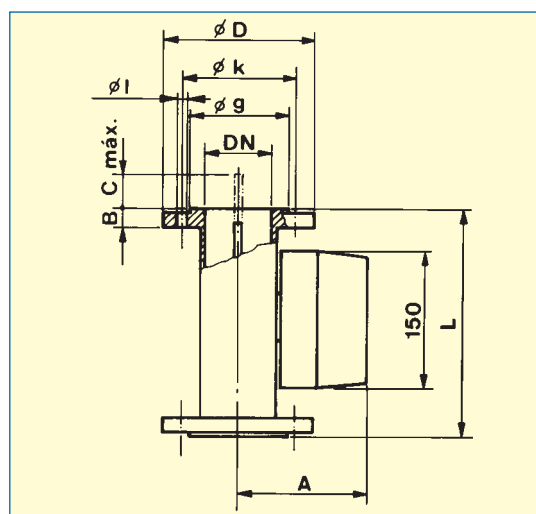
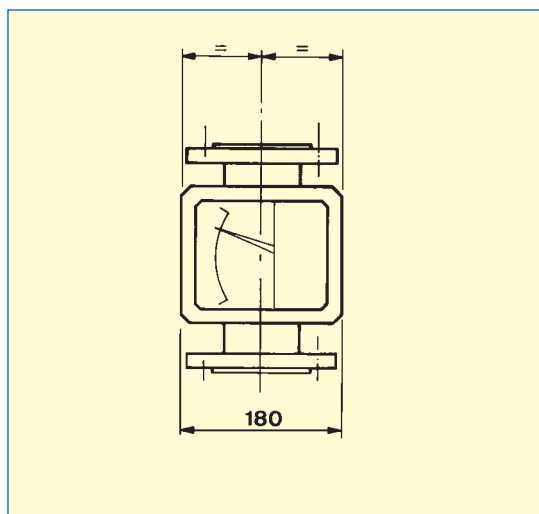

ASA Standard (Relationship between ASA and DIN in mm)

DN DIN	DN ASA	PN Flanges	D	k	g	lxn°	B	A	C	L	Weight Kg
15	3/4"	150	98.4	69.8	42.9	17x4	12.7	114	45	250	3.5
25	1 1/4"	150	117.5	88.9	63.5	17x4	15.9	120	45	250	4.5
40	2"	150	152.4	120.6	92.1	22x4	19.1	126	45	250	7.3
50	2"	300	165.1	127	92.1	22x8	22.2	130	45	250	8.3
65	2 1/2"	300	190.5	149.2	104.8	25x8	25.4	130	45	250	10
80	3"	300	209.5	168.3	127	25x8	28.6	142	45	250	12
100	4"	300	228.5	184.1	139.7	25x8	30.2	150	-	250	15
125	5"	150	254	200	157.2	25x8	31.8	162	-	250	20
150	6"	150	317.5	269.9	215.9	22.2x12	36.5	180	-	300	32

Alarm Options

Adjustable Micro Alarm, Series SC-AMM

Micro-switch bi-stable contact mounted in the indicator enclosure of the flow meter.

- SC-AMM1: 1 adjustable alarm contact.
- SC-AMM2: 2 adjustable alarm contacts.
- Load: 3 Amp @ 220Vac/50Hz.
- Temperature: -25°C to + 80°C.
- Hysteresis: ±10% of full scale.
- Mechanical life: 20 x 10⁶ Operations.
- Contact speed: 0.01 to 1 mSec.

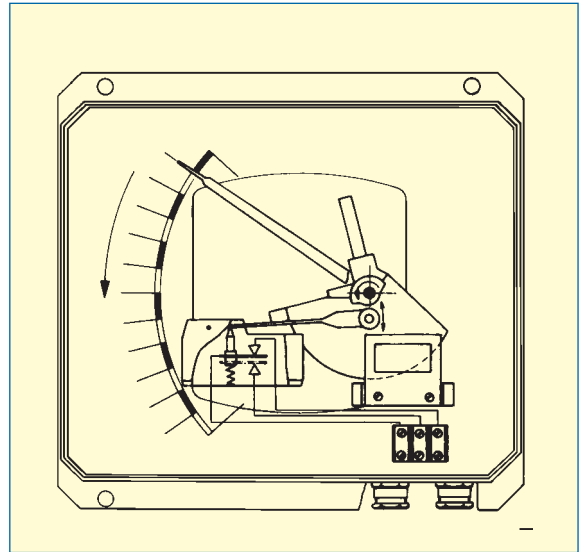

Adjustable Inductive Alarm, Series SC-AMD

Inductive proximity sensor, 3.5 mm, according to standard NAMUR DIN 19234, mounted in the indicator enclosure of the meter.

- SC-AMD1...2: 1 ... 2 adjustable alarm contacts.
(+ amplifier WE77/Ex1 or ExEx2).
- Power Supply: 8 Vdc.
- Temperature: -25°C to +70°C.

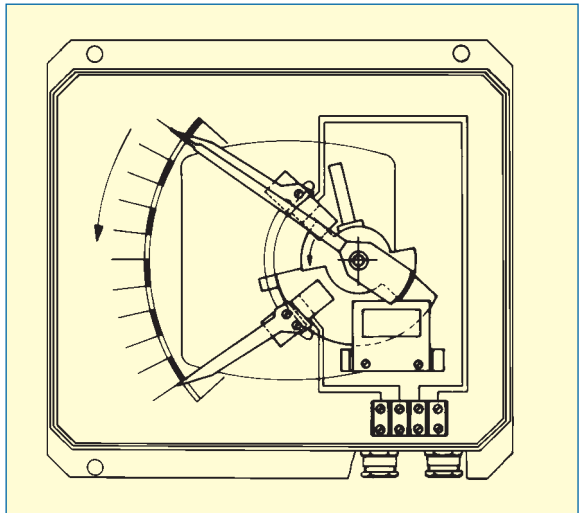

Relay for Inductive Proximity Sensor

Model WE77/EX 1: For 1 inductive alarm contact.
Model WE77/EX 2: For 2 inductive alarm contacts.

- Power Supply: 220Vac ±15%, 50-60Hz.
(other ac & dc voltages are also available)
- Intrinsic Safety Standard: EEx ia II C (Zone 0)
- Output: for 1 or 2 contacts.
- Load: 4 Amp @ 220Vac/250VA
- Temperature: -25 to +70°C.

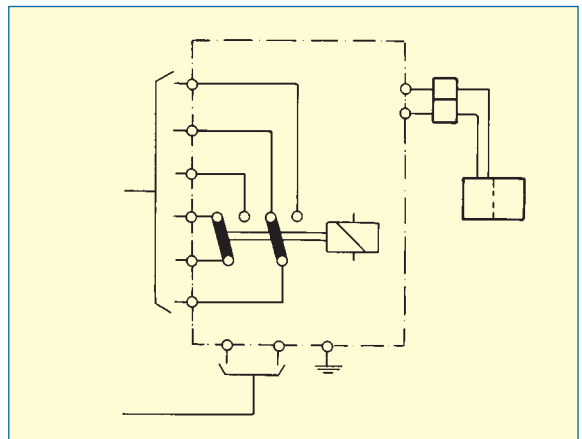

Transmitters

Electric Transmitter SC-TK-Ex

The electric transmitter TK-Ex is a two wire angular position converter. It provides a 4-20mA output signal directly proportional to the measured flow rate. Certified intrinsically safe to Cenelec EExibIIC T5/T6.

- Power supply: 12.7 to 36Vdc
- Load: 4mA + Output current
- Output signal: 4-20 mA
- Electrical connection: 2 wire
- Internal capacitance: $C_p < 15F$
- Ambient temperature: EEx ib CT4 70°C Max
CT5 65°C Max
CT6 50°C Max

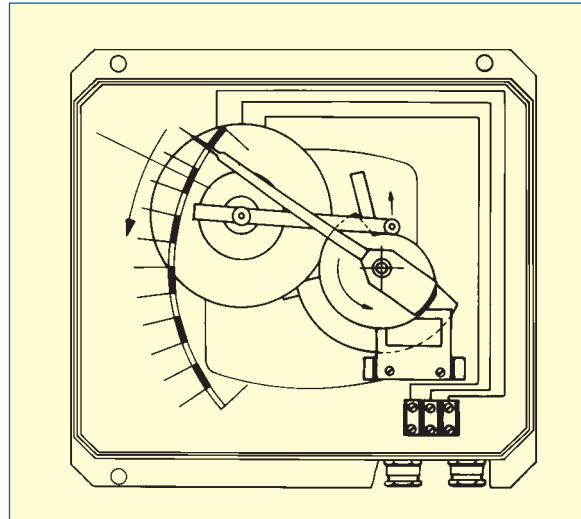

Electric Transmitter SC-TEH

Halltec Transducer based on a Hall effect pickup with zero friction on the indicating mechanism. Output signal directly proportional to the measured flow rate.

- Accuracy: 1,5% of the reading value
- Analog output available: 0..4-20 mA
0-5V, 0-10V, 1-5V, 2-10V
- Power suppliers: 24, 110, 220, 240 Vac, 50/60 Hz
24 Vdc
- Power consumption: < 3 w
- Ambient Temperature: -10 to + 60°C
- Electric connection: 4 wires

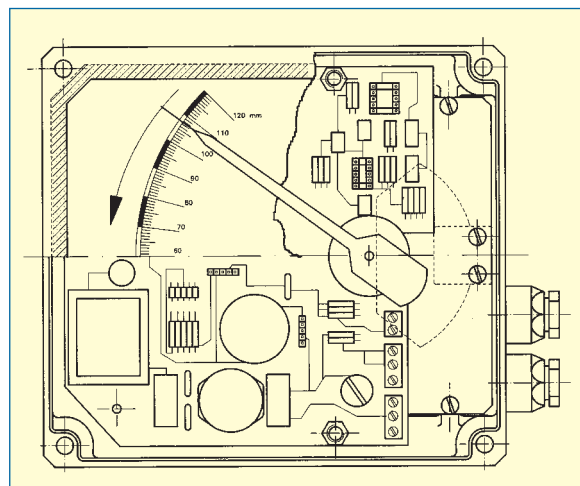

Pneumatic Transmitter SC-TP1200

The pneumatic transmitter SC-TP1200 provides a 3-15 psi or 0.2-1Bar pneumatic signal directly proportional to the measured flow rate.

- Air supply: Air 1.4 Bar \pm 0.1 Bar
- Consumption: 460 NI/h Air
- Output signal: 3-15psi (0.2-1Bar on request)
- Linearity: \pm 0.4%
- Hysteresis: \pm 0.25%
- Temperature: \pm 10°C to 70°C

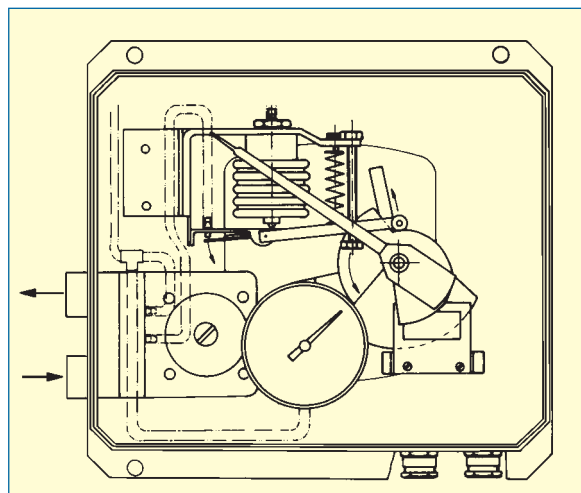



Totalizers

Halltec Transducer SC-TOTH/SC-TTEH

Based on a Hall effect pickup with zero friction on the indicating mechanism.

Totalizer SC-TOTH/SC-TTEH

The output signal 4-20 mA (or 0-20 mA) from the transmitters can be connected to an electronic counter either built into the indicator enclosure or mounted remotely.

SC-TOTH (Volume Totalizer)

- Electronic LCD counter 8 digits with reset.
- Digit height: 8 mm
- Accuracy: 1,5% of the reading value
- Pulse Output: TTL & open collector

SC-TTEH (Volume Totalizer + Analog Output)

- Electronic LCD counter 8 digits with reset.
- Digit height: 8 mm
- Accuracy: 1,5% of the reading value
- Analog Output Available: 0...4-20 mA
0-5V, 0-10V, 1-5V, 2-10V
- Pulse output: TTL & open collector

General Characteristics:

- Power Supplies: 24, 110, 220, 240 Vac, 50/60 Hz
24 Vdc
- Power Consumption: < 3w
- Ambient Temperature: -10 to +60°C

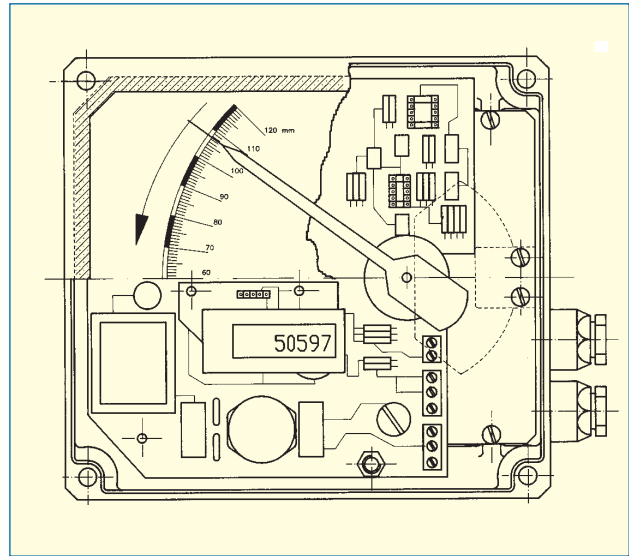

We are at your service, please consult us.
TECFLUID develops and manufactures instruments for gases and liquids, using the most advanced techniques.

FLOWMETERS

- Variable area with Glass metering tubes.
- Variable area with Metal metering tubes, and indication via magnetic transmission.
- Target disk and indication via magnetic transmission.
- Orifice disk.
- Electromagnetic.

COUNTERS

- COVOL (Oscillating piston)
- TM-44 (Turbine)

LEVELS

- Limit switches
- Indicators
- Transmitters

ELECTRONIC EQUIPMENT

- Converters
- Batching Counters
- Flow rate indicators
- Transmitters

In preparation:

- VORTEK

Request Information by telephone n° (34 3) 372 45 11



We are at your service, please consult us.
TECFLUID develops and manufactures instruments for gases and liquids, using the most advanced techniques.
Request Information by telephone n° 01 34 64 38 00

B.P. 27709 95046 CERGY PONTOISE CEDEX (FRANCE)
Tél. 01 34 64 38 00 – Fax. 01 30 37 96 86 Internet: www.tecfluid.fr